

TECHNICAL DATA
DATA SHEET 603, REV. -

HIGH VOLTAGE RECTIFIER STACKS

DESCRIPTION: A 4000/6000/8000/10000/11000/15000/20000 VOLT, 0.25 AMP, 70 NANOSECOND, HIGH VOLTAGE RECTIFIERS.

MAX RATINGS/ELECTRICAL CHARACTERISTIC ALL RATINGS ARE AT $T_A = 25\text{ C}$ UNLESS OTHERWISE SPECIFIED

RATING	SYMBOL	MAX.	UNITS
PEAK INVERSE VOLTAGE (PER LEG) SSCHE4000 SSCHE6000 SSCHE8000 SSCHE10000 SSCHE11000 SSCHE15000 SSCHE20000	PIV	4000 6000 8000 10000 11000 15000 20000	Volts
MAXIMUM FORWARD VOLTAGE DROP (PER LEG) ($I_f = 0.2\text{ Amps}$) SSCHE4000 SSCHE6000 SSCHE8000 SSCHE10000 SSCHE11000 SSCHE15000 SSCHE20000	V_f	10 15 20 25 30 40 50	Volts
MAXIMUM AVERAGE DC OUTPUT CURRENT ($T_C = 55\text{ }^\circ\text{C}$) When operating in oil, the output current capabilities are doubled.	I_o	0.25	Amps
MAXIMUM AVERAGE DC OUTPUT CURRENT ($T_C = 100\text{ }^\circ\text{C}$)	I_o	0.13	Amps
PEAK SINGLE CYCLE SURGE CURRENT $t_p = 8.3\text{ msec.}$	I_{PK}	20	Amps
MAXIMUM REVERSE CURRENT @ PIV ($T_A = 25^\circ\text{C}$)	I_{rr}	10	μA
MAXIMUM REVERSE CURRENT @ PIV ($T_A = 100^\circ\text{C}$)	I_{rr}	100	μA
MAXIMUM REVERSE RECOVERY TIME ($I_f = 0.5\text{A}$, $I_r = 1.0\text{A}$, $I_{rr} = 0.25\text{A}$)	t_{rr}	70	nsec
MAXIMUM OPERATING AND STORAGE TEMPERATURE RANGE	$T_{op, stg}$	-55 to +150	$^\circ\text{C}$

SENSITRON

TECHNICAL DATA
DATA SHEET 603, REV. -

MECHANICAL DIMENSIONS: In Inches / mm

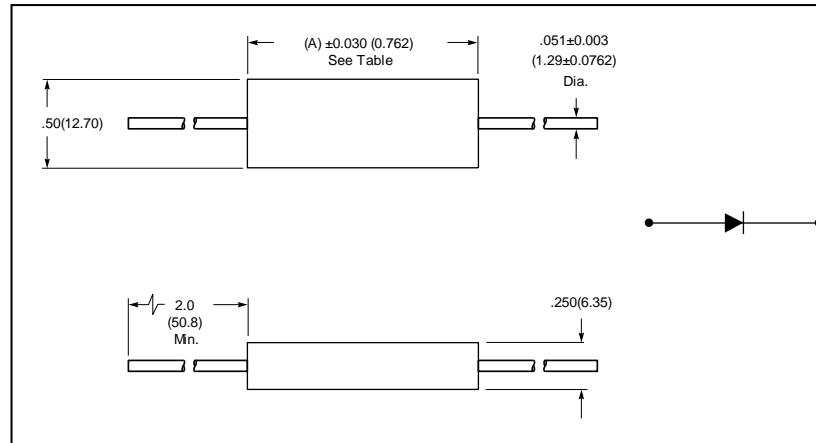

FIG. 418

* Case Material: Molded Epoxy

Table A

Type Number	Package Length
SSCHE4000	1.125
SSCHE6000	1.625
SSCHE8000	2.000
SSCHE10000	2.375
SSCHE11000	2.750
SSCHE15000	3.500
SSCHE20000	4.250

DISCLAIMER:

- 1- The information given herein, including the specifications and dimensions, is subject to change without prior notice to improve product characteristics. Before ordering, purchasers are advised to contact the Sensitron Semiconductor sales department for the latest version of the datasheet(s).
- 2- In cases where extremely high reliability is required (such as use in nuclear power control, aerospace and aviation, traffic equipment, medical equipment, and safety equipment), safety should be ensured by using semiconductor devices that feature assured safety or by means of users' fail-safe precautions or other arrangement.
- 3- In no event shall Sensitron Semiconductor be liable for any damages that may result from an accident or any other cause during operation of the user's units according to the datasheet(s). Sensitron Semiconductor assumes no responsibility for any intellectual property claims or any other problems that may result from applications of information, products or circuits described in the datasheets.
- 4- In no event shall Sensitron Semiconductor be liable for any failure in a semiconductor device or any secondary damage resulting from use at a value exceeding the absolute maximum rating.
- 5- No license is granted by the datasheet(s) under any patents or other rights of any third party or Sensitron Semiconductor.
- 6- The datasheet(s) may not be reproduced or duplicated, in any form, in whole or part, without the expressed written permission of Sensitron Semiconductor.
- 7- The products (technologies) described in the datasheet(s) are not to be provided to any party whose purpose in their application will hinder maintenance of international peace and safety nor are they to be applied to that purpose by their direct purchasers or any third party. When exporting these products (technologies), the necessary procedures are to be taken in accordance with related laws and regulations.