

100V, 100A, Solid State DC Contactor

Applications:

- Main DC Bus Switch
- DC Motor Bus Switch
- Battery Disconnect
- Bus Discharge
- DC Contactor

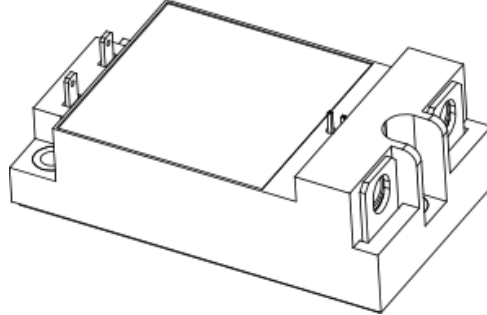

Description:

Sensitron has developed a small footprint High Voltage/High Current DC solid state Relay/Contactor. This device incorporates the latest state of the art technology to reduce the “on” state power losses and voltage drop to a minimum. The device is a true four terminal relay, not needing additional power sources for bias. This device uses robust magnetic coupling to achieve high isolation, reliability, and long life. Unlike opto-isolation techniques this device will not degrade with time. The input control lead will accept any voltage from 4.6V to 36VDC.

Features:

- 2000V Input to Output Isolation
- 100V Blocking, 100A Continuous Current
- 800A Surge Capability
- -55°C to 100°C Operation
- Single wide range DC input signal 4.6V to 36V
- Low Power Control, 0.5W Typ.
- True Four Terminal Operation
- Low “on” state resistance 1.5 m-ohms
- Fast turn on/turn off, less than 1us
- High Current Terminals
- Three Point Mounting Plate
- $R_{\theta JC} \leq 0.4^{\circ}\text{C/W}$
- 1.4” x 2.6” x .5”

Input Control Specifications:

Parameter	Description	MIN	TYP	MAX	Unit
V_{control}	DC Control Voltage Between pins 1 and 2	4.6		36	Volts
I_{control}	Input Current at control pins 1 and 2, $V_{\text{in}} = 4.6\text{V to }36\text{V}$	10	25	150	mA
P_{control}	Control Input Power Consumption		0.5	0.69	Watt
Gain	$I_{\text{out}}/I_{\text{in}}$, $V_{\text{in}}=12\text{V}$ $V_{\text{in}}=28\text{V}$		2400 5600		

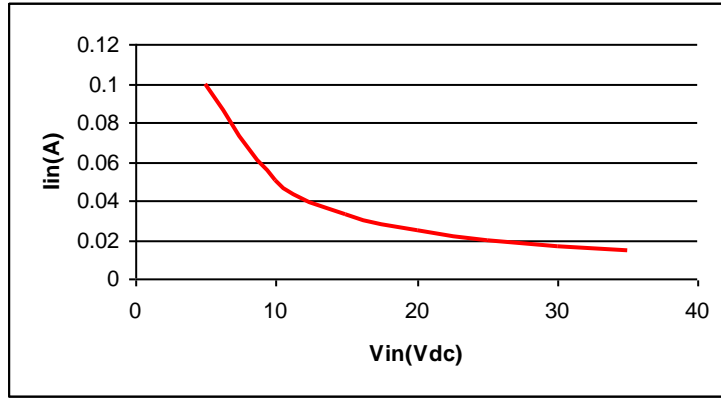

Fig. 1-Typical Input Current vs. Input Volt

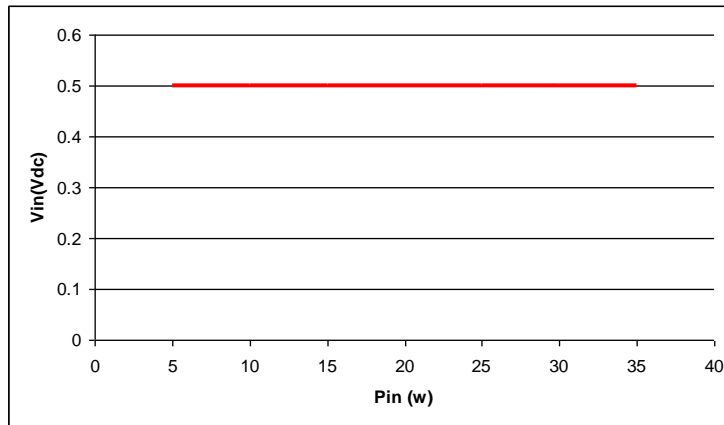

Fig.2- Typical Control Input Power

Output Specifications:

Parameter	Description	MIN	TYP	MAX	Unit
V _{out}	Blocking Voltage Across Pins 3 and 4	100			Vdc
I _{leak}	Output leakage at V _{out} =100V, T _j =25 °C T _j =150 °C			250 1000	uA dc
I _{out}	“Contact” Current	0		100	Adc
I _{surge}	Output Surge Current Capability		800		A peak
R _{on}	“Contact Resistance” I _o =100A, T _j =25 °C T _j =150 °C			0.0015 0.0035	Ohm
V _{drop}	Voltage drop at I _o =100A			0.4	Vdc
C _{out}	Capacitance, V _{DS} =50 V, f=1MHz		2010		pF
I _{latch}	Over Current latch, at 25 °C		800		A(peak)
E _{AS}	Avalanche energy, single pulse			190	mJ
V _{SD}	Reverse Diode Vf, I _o =75 A, T _j =25 °C			1.3	Vdc
t _{rr}	Reverse recovery time		60		ns

TECHNICAL DATA
DATASHEET 5450, REV. -

Switching Characteristics:

Parameter	Description	MIN	TYP	MAX	Unit
t_{on}	"Contact" turn on time		0.4	1	us
t_{off}	"Contact" turn off time		0.4	1	us
t_{don}	Delay from input command to contact on		1.5		ms
t_{doff}	Delay from input command to contact off		0.5		ms
t_{dlatch}	Delay to latch after detection of Over Current		50		us
F_{switch}	Repetitive on to off switching frequency		600		Hz

Block Diagram

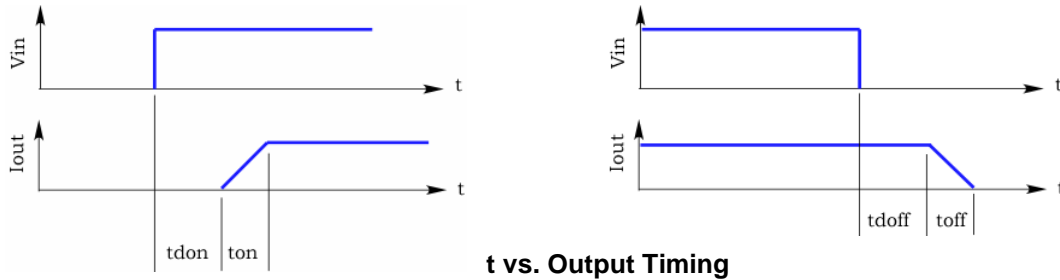
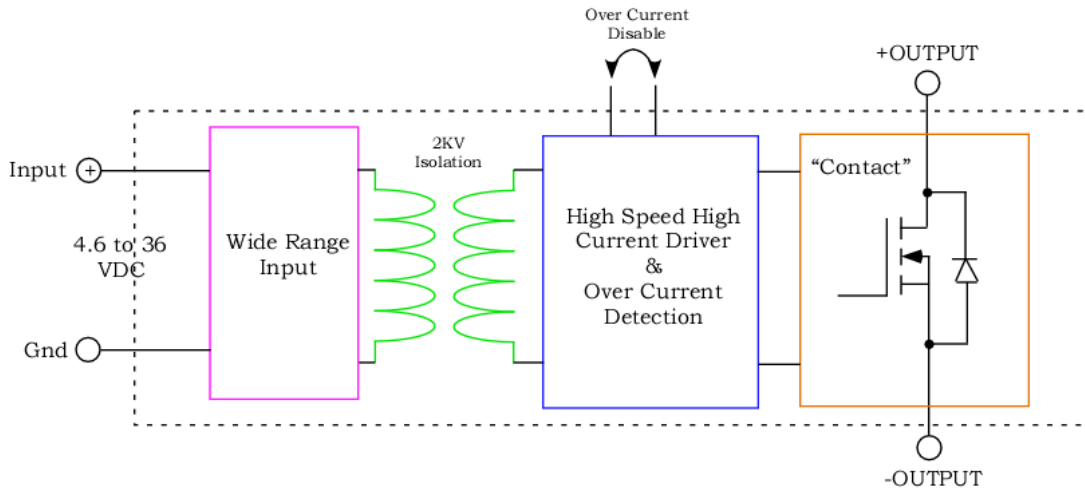

t vs. Output Timing

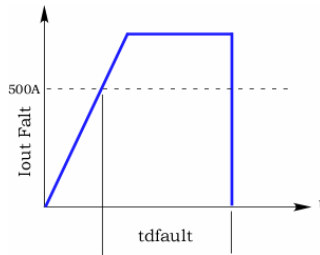
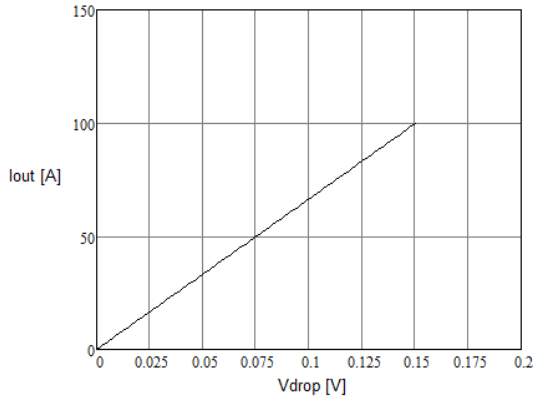

Fig.4 – Over Current Fault Shut Down

TECHNICAL DATA
DATASHEET 5450, REV. -

Typical Vdrop vs. Current @Tj=25C



Typical Vdrop vs. Current @Tj=150C

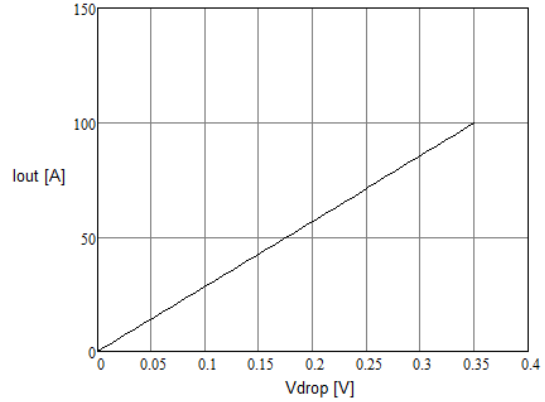

Typical Ron vs. Temp

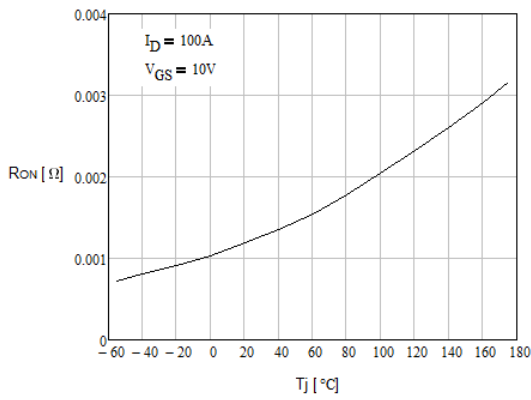

Blocking Voltage vs. Temp

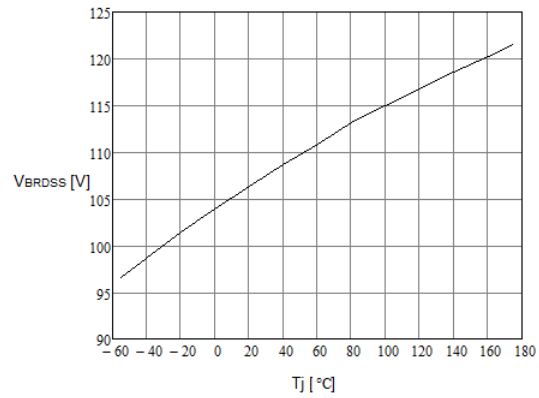

Environmental

Parameter	Description	MIN	TYP	MAX	Unit
Top	Operating Temperature (base Plate)	-55		100	°C
Tstg	Storage Temperature	-55		125	°C
Isolation	Input to Output	2000			VDC
Isolation	Input or Output to Case	2000			VDC
RθJC	Thermal Resistance		0.33	0.4	°C/W

Mechanical Outline

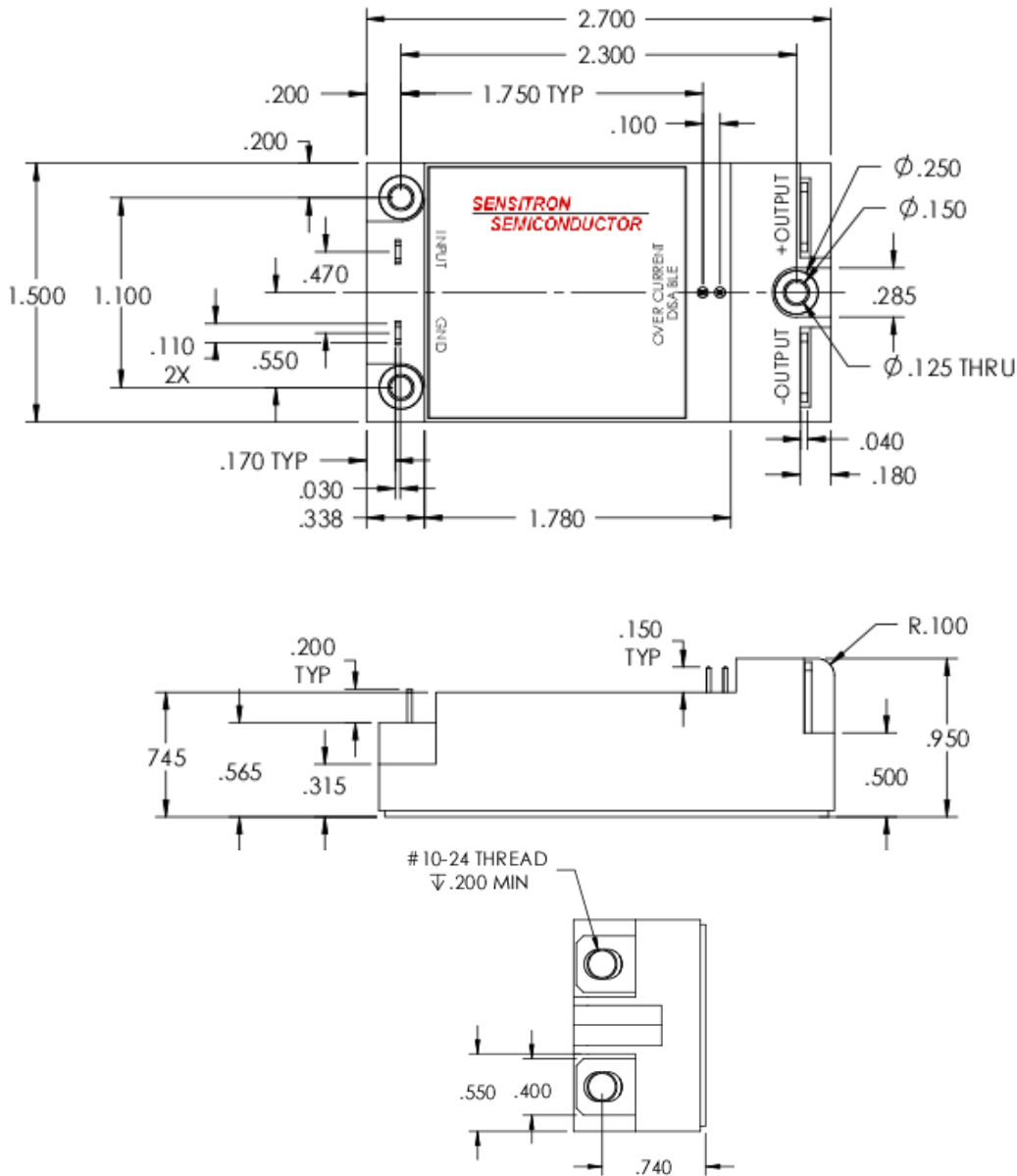

Pin Assignments:

Input – Apply a positive voltage to this pin with respect to pin Gnd to “close” the contacts.

Gnd – This is the return pin for the Input control voltage.

+OUTPUT – This is the positive terminal of the “contact”.

-OUTPUT – this is the return terminal for the +OUTPUT pin.

Note:

1. Input pins and output pins are isolated up to 2000VDC
2. The device may be damaged if the input polarity is reversed.
3. The “contact” is uni-polar; a voltage reversal will result in current flow in the internal diode.

Application Notes:

TECHNICAL DATA
DATASHEET 5450, REV. -

A. Input Bias

The SSR100D010 will be energized and the "Contact" will be closed, when a positive potential of 4.6VDC to 36VDC is applied between Input and Gnd. The input power consumption will be constant through out the control voltage range therefore the contactor will draw more current at lower control voltages.

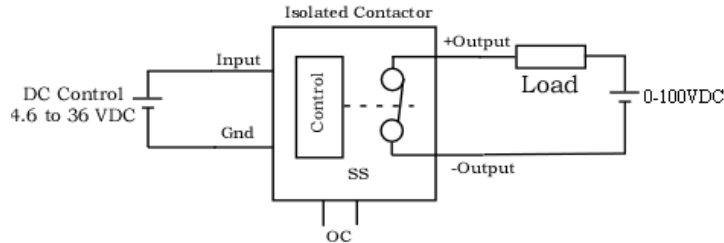

DC Supply

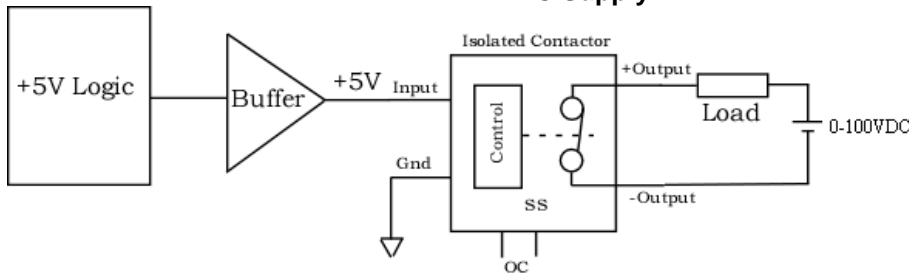

TTL with Buffer

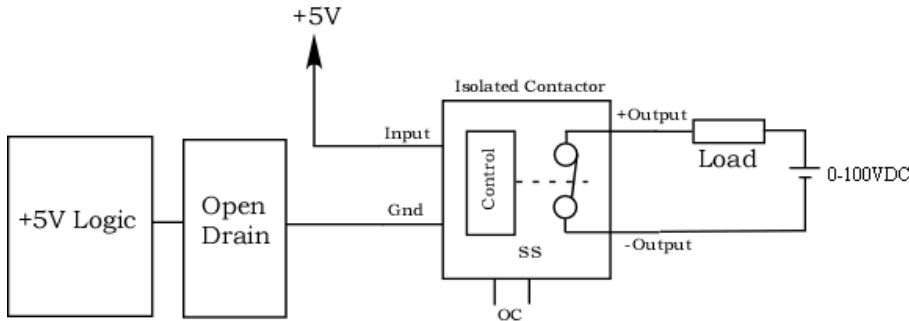

Input Driven from TTL with Open Drain Driver

B. Output Load Connection

The output circuit is completely floating therefore the Load can be connected to either output terminal.

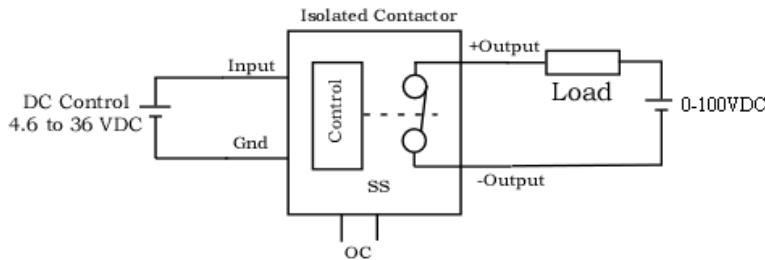

Load connected to +Output Terminal

TECHNICAL DATA
DATASHEET 5450, REV. -

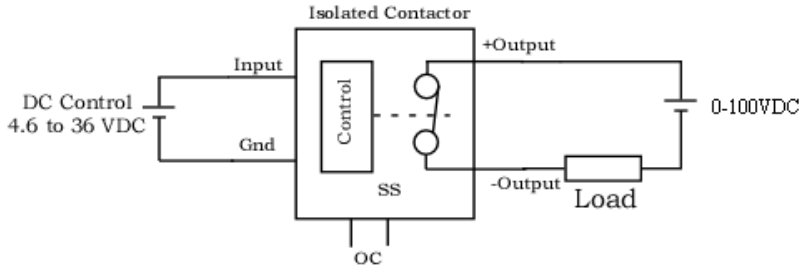

Load Connected to -Output Terminal

C. Over Current Disable

The SSR100D010 contains an Over Current latch which disables (opens) the contact whenever a large current in excess of 800A is detected. The latch can only be reset by removing and re-applying the input control power. In noisy environments and in applications where high surge currents are encountered, the latch may be triggered prematurely. In these applications the latch circuit can be disabled by placing a short circuit between the over current disable terminals.

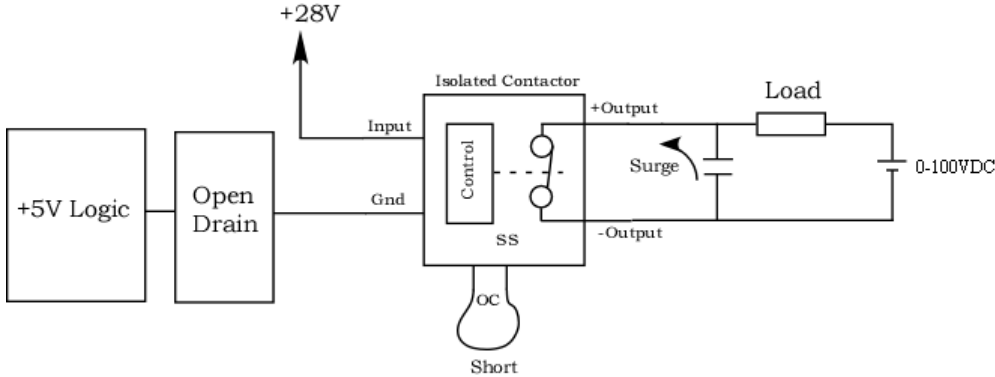

D. Contact Protection

The user must insure that the peak voltage rating of the SSR100D010 is not exceeded. The SSRXXDXXX family of devices switch at extremely fast speeds, therefore extra care must be taken to suppress voltage transients that are generated when interrupting high currents. Sensitron strongly advises the user to use a snubber network similar in design to the one shown below. This is an energy absorbing snubber that transfers the energy from any parasitic line inductance into the capacitor and then is dissipated through the resistor. The capacitor should be sized so that the captured energy does not charge the capacitor beyond the contacts rated voltage.

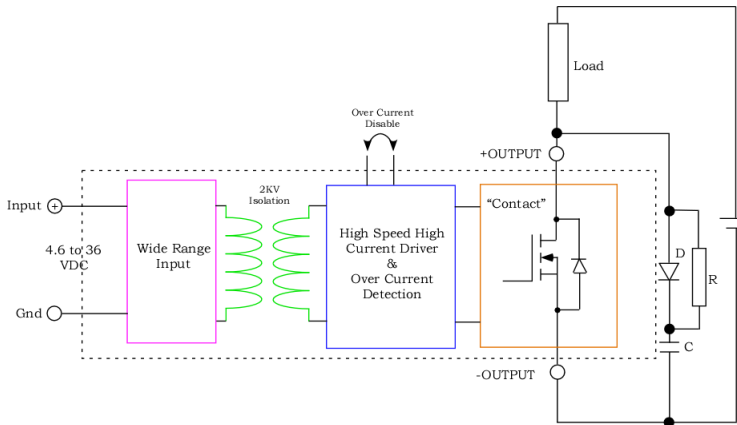

TECHNICAL DATA
DATASHEET 5450, REV. -

E. AC Operation

The contactor can be used for AC loads if two devices are connected “back to back”.

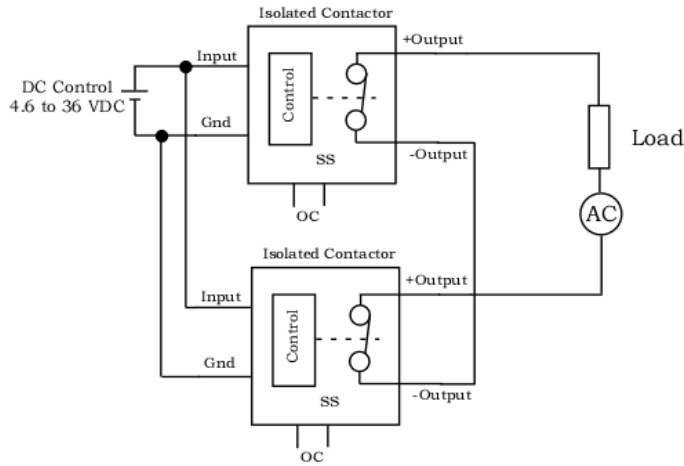

DISCLAIMER:

- 1- The information given herein, including the specifications and dimensions, is subject to change without prior notice to improve product characteristics. Before ordering, purchasers are advised to contact the Sensitron Semiconductor sales department for the latest version of the datasheet(s).
- 2- In cases where extremely high reliability is required (such as use in nuclear power control, aerospace and aviation, traffic equipment, medical equipment, and safety equipment), safety should be ensured by using semiconductor devices that feature assured safety or by means of users' fail-safe precautions or other arrangement.
- 3- In no event shall Sensitron Semiconductor be liable for any damages that may result from an accident or any other cause during operation of the user's units according to the datasheet(s). Sensitron Semiconductor assumes no responsibility for any intellectual property claims or any other problems that may result from applications of information, products or circuits described in the datasheets.
- 4- In no event shall Sensitron Semiconductor be liable for any failure in a semiconductor device or any secondary damage resulting from use at a value exceeding the absolute maximum rating.
- 5- No license is granted by the datasheet(s) under any patents or other rights of any third party or Sensitron Semiconductor.
- 6- The datasheet(s) may not be reproduced or duplicated, in any form, in whole or part, without the expressed written permission of Sensitron Semiconductor.
- 7- The products (technologies) described in the datasheet(s) are not to be provided to any party whose purpose in their application will hinder maintenance of international peace and safety nor are they to be applied to that purpose by their direct purchasers or any third party. When exporting these products (technologies), the necessary procedures are to be taken in accordance with related laws and regulations.