

TECHNICAL DATA
DATASHEET 5100, Rev -

28V DC Solid State Power Controller Module

Description:

These Solid State Power Controller (SSPC) Modules are designed to operate without any heatsink requirements. They are microcontroller-based Solid State Relays rated up to 25A designed to be used in high reliability 28V DC applications. These modules have integrated current sensing with no derating over the full operating temperature range. These modules are the electronic equivalent to electromechanical circuit breakers with isolated control and status. This series is supplied in 5 SSPC current levels. The 7A model is available with failsafe operation (non-latching)

SRPC0.5D28	28VDC	0.5A	Latching
SRPC2D28	28VDC	2A	Latching
SRPC7D28	28VDC	7A	Latching
SRPC15D28	28VDC	15A	Latching
SRPC25D28	28VDC	25A	Latching
SRPC7D28F	28VDC	7A	Non-Latching

Module Features:

- No additional heat sinking or external cooling required
- Extremely Low Power, No Derating Over the Full Temperature Range
- Potted Module
- Solid State Reliability

Electrical Features:

- 28VDC Input with Very Low Voltage Drop; 180mV, max. @ 25A
- True I²t Protection up to 17X rating with Nuisance Trip Suppression
- Instant Trip Protection (200 μsec typ)
- Unlimited Interrupt Capability; Repetitive Fault Handling Capability
- Thermal Memory
- Internally Generated Isolated Supply to Drive the Switch
- Low Aux Supply Current: 10 mA typ @ 5V DC
- High Control Circuit Isolation: 100V DC Control to Power Circuit
- Soft Turn-On to Reduce EMC Issues
- EMI Tolerant
- Input control doubles as reset; Reset Circuit is Trip-Free
- TTL/CMOS Compatible, Optically Isolated, Input and Outputs

TECHNICAL DATA
DATASHEET 5100, Rev -

Table 1: Electrical Characteristics (at 25°C and VAUX = 5.0V DC unless otherwise specified)

Control & Status (TTL/CMOS Compatible)	
AUX Supply (Vcc)	5.0V DC Nominal, 7V DC Absolute Maximum 4.5V to 5.5 VDC
AUX Supply (Vcc) Current	10 mA typ 20 mA, max
Status & BIT/TRIP Signals	V _{oh} =3.7V, min, at I _{oh} = -8mA V _{ol} =0.4V, max, at I _{ol} = 2mA
CONTROL Signal V _{IL} V _{IH} R _{IN}	0.8V, max 2V, min 101 kOhm, typ
Power	
Input Voltage – Continuous – Transient	9V to 40V DC, 43V DC Absolute Maximum +100V or –100V Spike (< 10 μs)
Power Dissipation	See Table 5
Current	See Table 5 See Trip Curves, Figure 1, Figure 2, Figure 3
Max Voltage Drop	See Table 5
Max current without tripping	110% min
Trip time	See Trip Curves, Figure 1, Figure 2, Figure 3
Protection	
Instant Trip	See Trip Curves, Figure 1, Figure 2, Figure 3

Table 2: Physical Characteristics

Temperature	
Operating Temperature	T _A = -40 °C to +100 °C
Storage Temperature	T _A = -55 °C to +125 °C
Environmental	
Altitude	Up to 30,000 ft Can be installed in an unpressurized area
Case Dimensions	2.00" x 1.95" x 0.44"
Weight	60 grams typ, 140 grams max

TECHNICAL DATA
DATASHEET 5100, Rev -

Figure 1: Trip Curve for SRPC0.5D28 and SRPC2D28

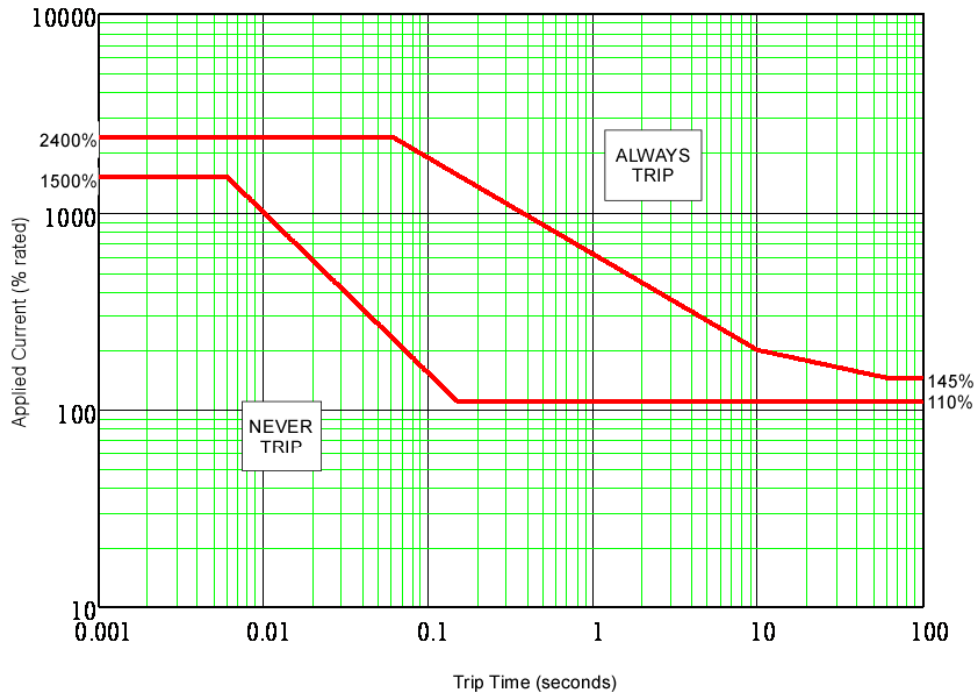
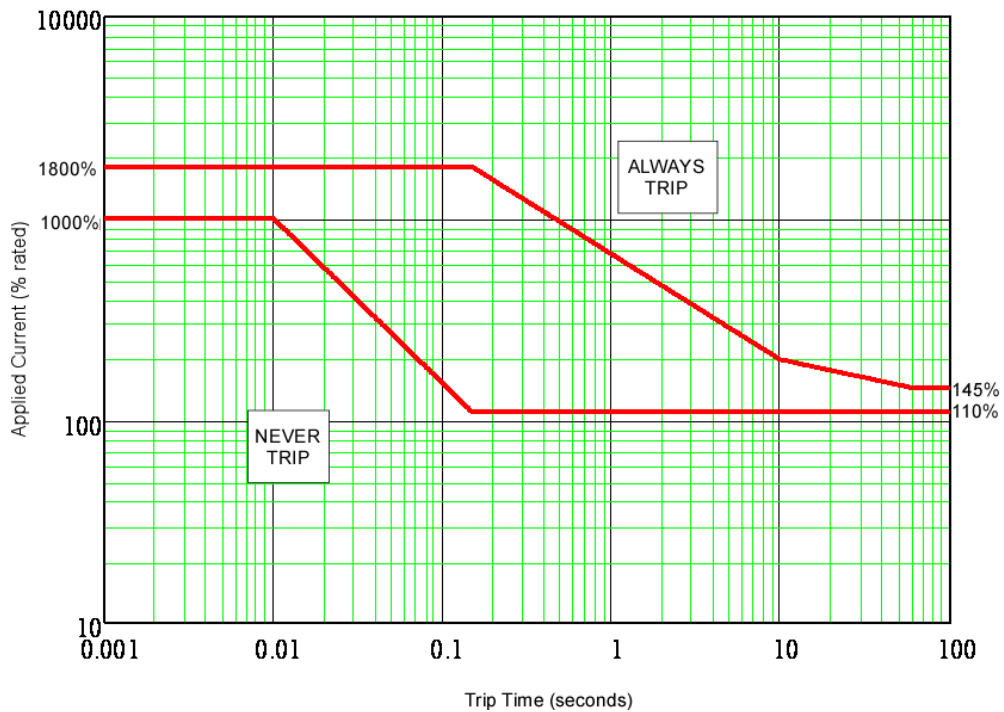

Figure 2: Trip Curve for SRPC7D28 and SRPC7D28F



TECHNICAL DATA
DATASHEET 5100, Rev -

Figure 3: Trip Curve for SRPC15D28 and SRPC25D28

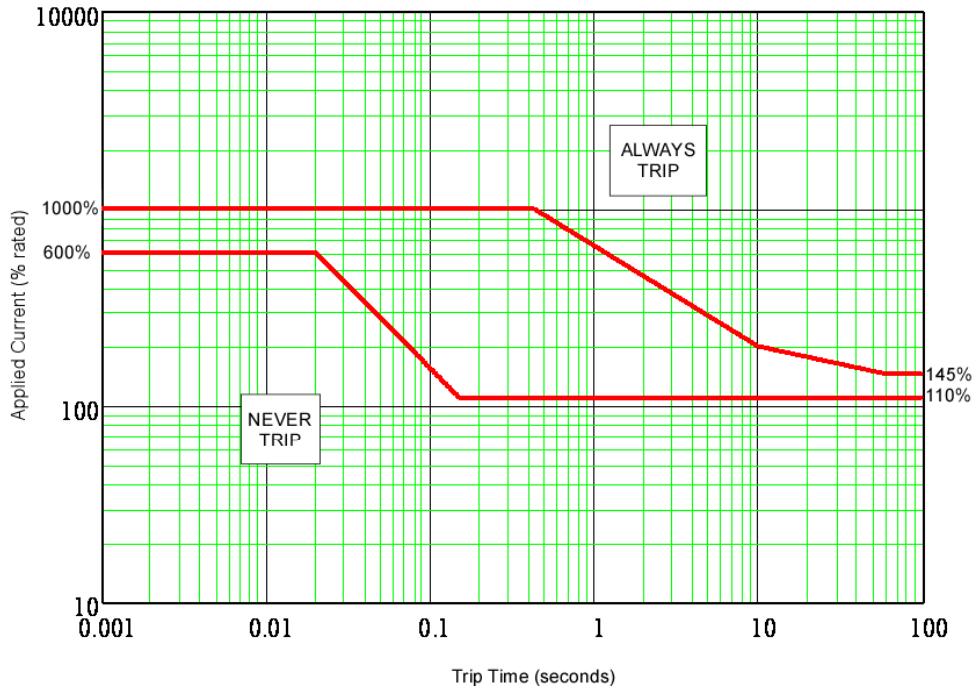
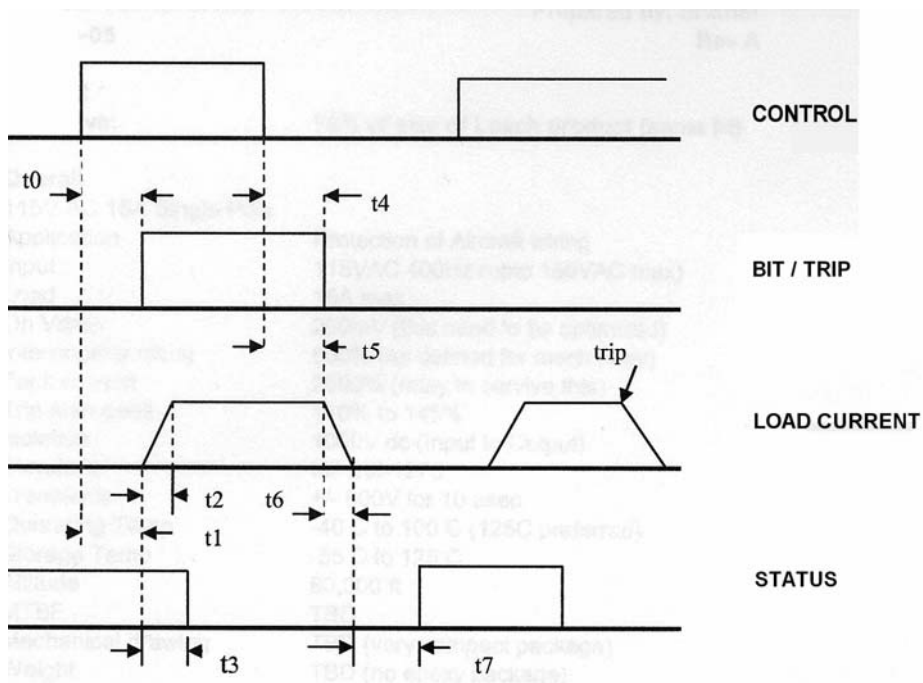

Figure 4: Timing Diagram



TECHNICAL DATA
DATASHEET 5100, Rev -

Table 3: Signal Timing (-40°C to 100°C, 28VDC_IN = 28VDC)

Parameter	Symbol	Min	Max	Units
CONTROL to GATE Status Delay for Turn On	t0		500	μs
Turn ON Delay	t1		1	ms
Load Current Rise Time	t2	50	200	μs
Turn ON to LOAD Status Delay	t3		2	ms
CONTROL to GATE Status Delay for Turn Off	t4		500	μs
Turn OFF Delay	t5		1	ms
Load Current Fall Time	t6	50	200	μs
Turn OFF to LOAD Status Delay	t7		2	ms

Note: Current Fall Time from trip is dependent on magnitude of overload

All dimensions are in inches

Figure 5: SRPC0.5D28 Mechanical Dimensions / Connector Keying

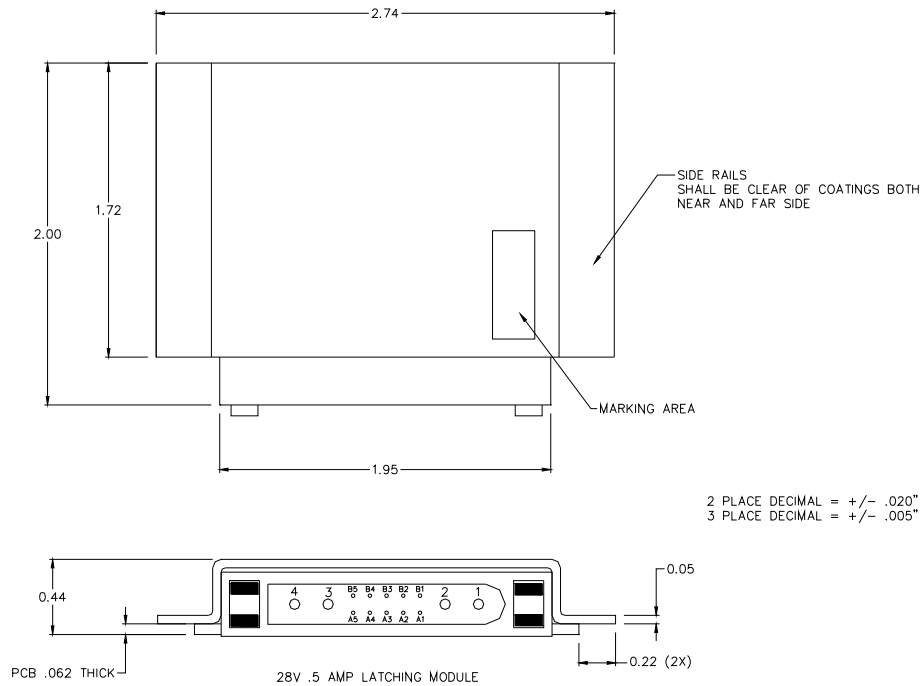

TECHNICAL DATA

DATASHEET 5100, Rev -

Figure 6: SRPC2D28 Mechanical Dimensions / Connector Keying

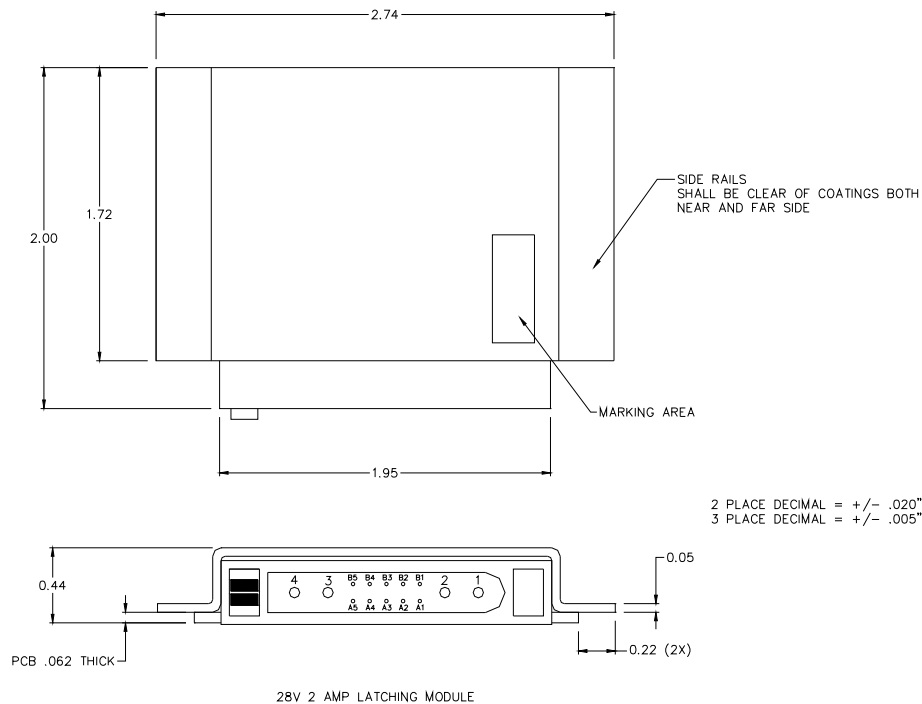
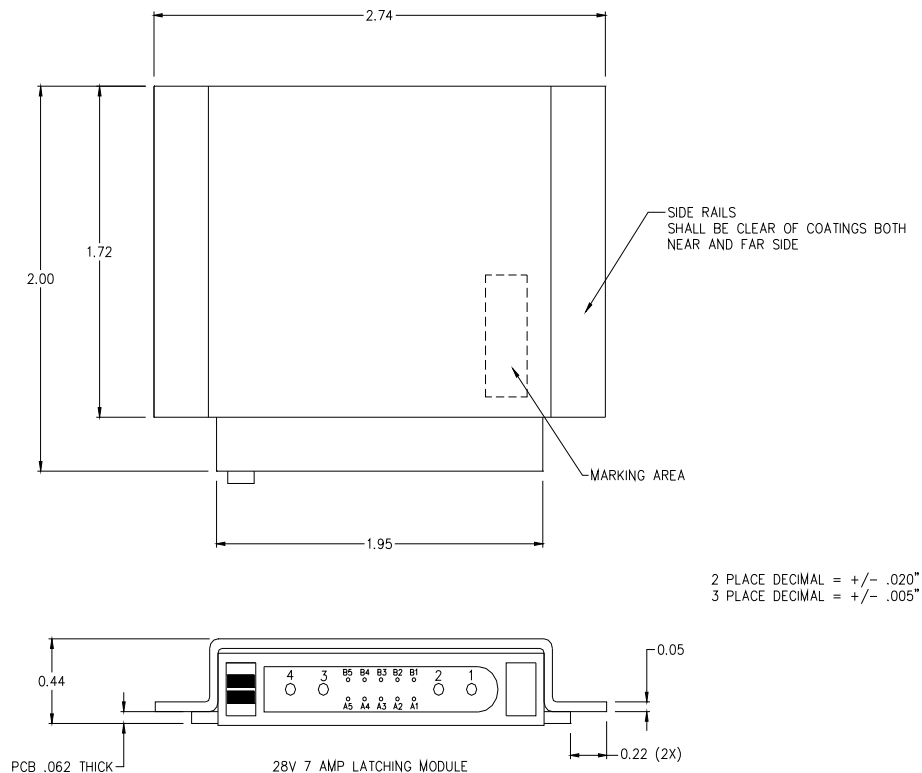

Figure 7: SRPC7D28 Mechanical Dimensions / Connector Keying



TECHNICAL DATA

DATASHEET 5100, Rev -

Figure 8: SRPC7D28F Mechanical Dimensions / Connector Keying

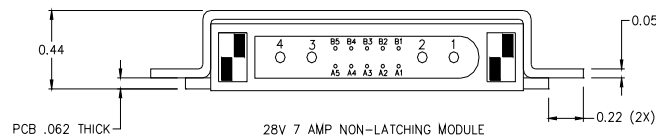
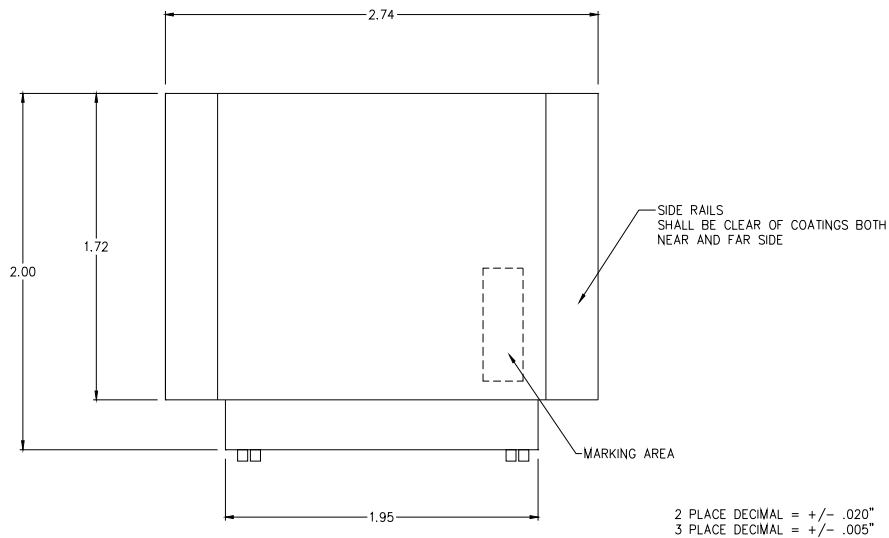
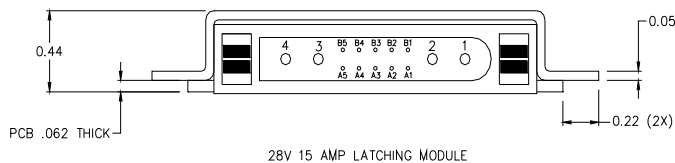
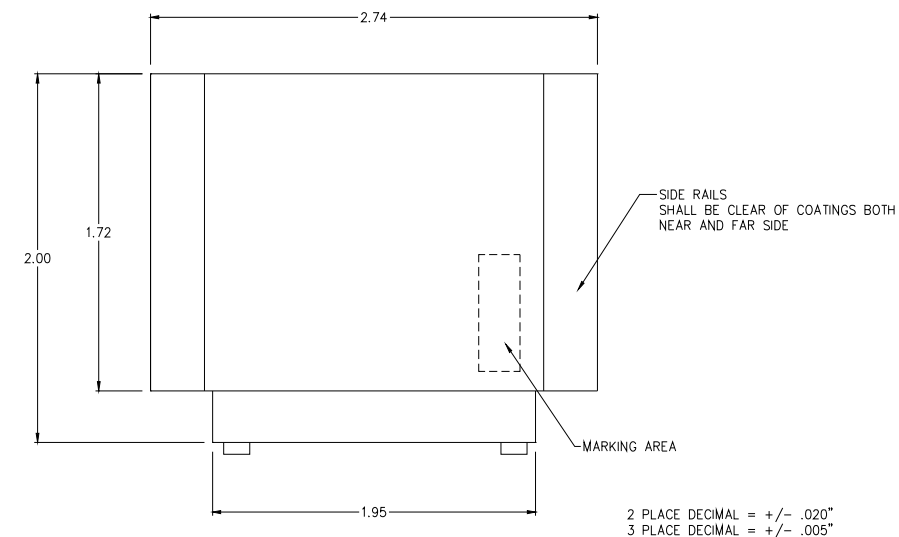

Figure 9: SRPC15D28 Mechanical Dimensions / Connector Keying



TECHNICAL DATA

DATASHEET 5100, Rev -

Figure 10: SRPC25D28 Mechanical Dimensions / Connector Keying

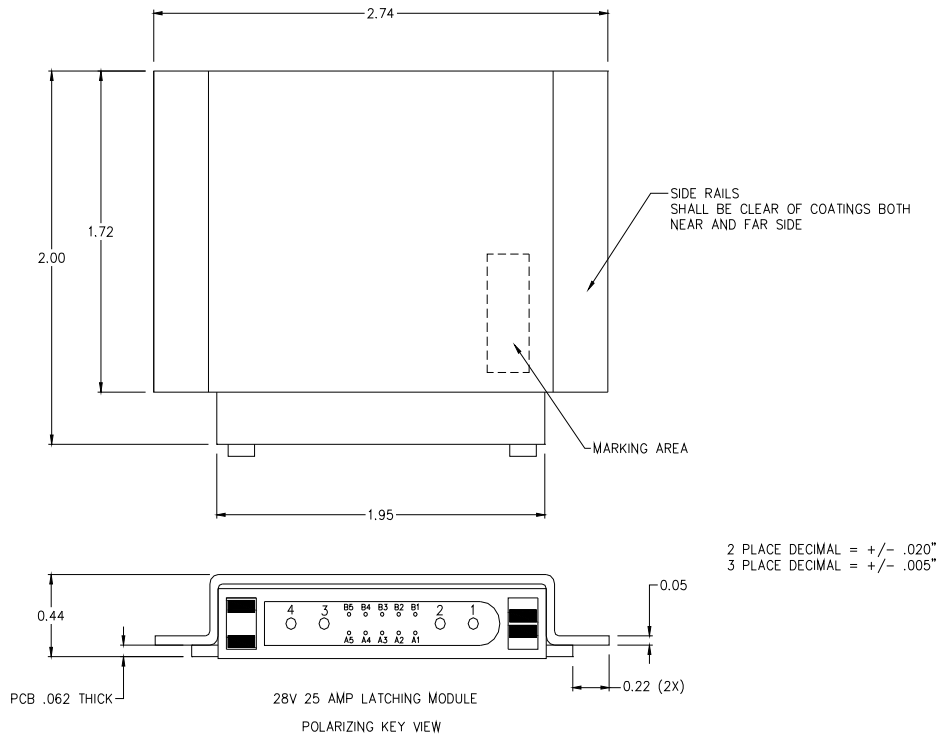

Table 4: Pin Definitions

Pin Number	Pin Name	Function
1	28V DC, IN	POWER IN
2	28V DC, IN	POWER IN
3	28VDC, LOAD	LOAD
4	28VDC, LOAD	LOAD
A1	NC	No Connection
A2	NC	No Connection
A3	NC	No Connection
A4	NC	No Connection
A5	28V RETURN	POWER RTN
B1	AUX. IN (5VDC)	DC Bias Supply
B2	AUX. COMMON	DC Bias Supply Return
B3	BIT/TRIP	Switch Status Output
B4	STATUS	Load Status Output
B5	CONTROL	Control Input

TECHNICAL DATA
DATASHEET 5100, Rev -

Table 5: Model Current Rating, Power Dissipation, Voltage Drop

Model	Current Rating	Pdiss 25°C	Pdiss 100°C	Vdrop 25°C	Vdrop 100°C
SRPC0.5D28	0.5 A	1 W max	1 W max	33 mV max	34 mV max
SRPC2D28	2 A	1 W max	1 W max	40 mV max	45 mV max
SRPC7D28	7 A	1.6 W max	1.75 W max	90 mV max	100 mV max
SRPC15D28	15 A	3 W max	3.5 W max	130 mV max	140 mV max
SRPC25D28	25 A	5.4 W max	6 W max	180 mV max	200 mV max
SRPC7D28F	7 A	1.6 W max	1.75 W max	90 mV max	100 mV max

Figure 11: Electrical Block Diagram

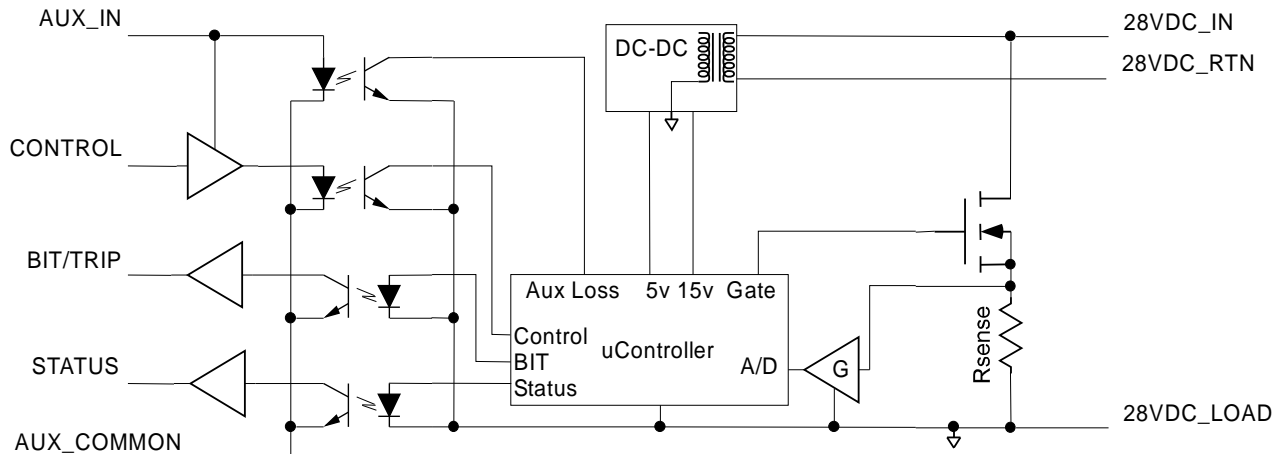

Description

Figure 11 shows the block diagram of the GD SSPC Series. A 74HCT1G04 device is used for the CONTROL input and the BIT/TRIP and STATUS digital outputs. These digital I/O are TTL and CMOS compatible. The outputs can each drive more than 1 standard TTL loads. This digital circuitry is optically isolated from the 28V power and the microcontroller circuitry.

Isolated power for the microcontroller electronics is generated from the DC-DC converter off of the 28VDC_IN power. This isolated power is referenced to the 28VDC_LOAD output of the SSPC.

Load current is measured by the microcontroller using an integrated A/D, a voltage amplifier, 'G', and a current sense resistor, Rsense. The microcontroller code implements a precision I²t protection curve as well as an Instant Trip function. This circuit breaker action protects the user application wiring as well as the power components of the SSPC itself. The microcontroller performs all of the functions of multiple analog comparators and discrete logic in one high-reliability component. The STATUS output is set active when >10% rated load current is measured and inactive otherwise.

The I²t software algorithm in the microcontroller performs a reading at the A/D converter, squares this reading, and applies it to a simulated RC circuit. The algorithm trips the output (turns off the power Mosfets) when the

TECHNICAL DATA

DATASHEET 5100, Rev -

simulated RC output becomes too high. Because the microcontroller simulates an analog RC circuit, the SSPC has 'thermal memory'. That is, it trips faster if there had been current flowing prior to the overload than if there hadn't been current flowing. This behavior imitates thermal circuit breakers and better protects the application's wiring since the wiring cannot take as much of an overload if current had been flowing prior to the overload.

The CONTROL input is monitored by the microprocessor. When this input is active, the power mosfet is turned on. When inactive, the mosfet is turned off. The turning on of the mosfet is overridden if an I^2t overload or instant trip condition are detected. In either of these conditions the mosfet is turned off independently of the CONTROL input and may not be turned on again until a 'reset' is performed.

The BIT/TRIP output goes active whenever the mosfet is turned on and inactive whenever the mosfet is turned off.

The AUX LOSS input is used to detect loss of AUX_IN power. For the latching models (all but SRPC7D28F), when AUX LOSS is detected, the mosfet state is held on/off based on the last CONTROL input on/off that was detected. The SPRC7D28F ignores this input.

The microcontroller has a watchdog timer that can detect certain types of failures in software execution. The software programmed in the microcontroller is set to periodically reset the free running watchdog timer. If the software malfunctions in such a way that the watchdog timer cannot be reset, the watchdog times out and resets the processor hardware. The watchdog timer operates from its own internal clock so a failure of the main internal clock will not stop the watchdog timer. On watchdog timeout the processor will restart just as if 28V power had been lost and restored. Since the code is designed to detect levels and not edges on the Control input, the output of the SSPC immediately reflects the state of the Control input after reset.

The Power Mosfets used in the SSPC have been selected for very low $R_{ds(on)}$. This results in low voltage drop across and low power dissipation in the SSPC. In most applications, the Mosfets will be operated at 50% to 60% of rated current to provide a safety margin. As can be seen in Table 5, when the **SRPC25D28** is operated at 25 Amps, it only dissipates 3.0 Watts at room temperature. When operated at 60% rated current, the I^2R power reduces to just over 1 Watt. No heat sinking is required for this condition. Each application should be evaluated at maximum expected constant current. Because the mosfet's are thermally attached to the module metal lid, temperature rise from power dissipation may be controlled by headsinking the lid. The lower current models in the series (7A and below) do not require heat sinking under all conditions.

For overloads, no heat sinking is required provided the SSPC is allowed some time to cool down. The design has sufficient thermal mass that the temperature will rise only a few degrees under the worst-case overload. Repetitive overloads should be avoided. When the SSPC reports a trip condition, the controller driving the SSPC should allow no more than four repetitions and then allow thirty seconds to cool down before trying to turn on again.

The SSPC will trip on overloads in the ALWAYS TRIP region shown in the trip curves of Figure 1, Figure 2, and Figure 3. The SSPC will never trip when operated in the NEVER TRIP region. When overload occurs, the SSPC will trip, turning off the output mosfet. The SSPC mosfet will remain off until reset. The SSPC can be reset by bringing the CONTROL pin to a logic low. When the CONTROL pin is brought back to logic high, the SSPC will turn back on. If the overload is still present, the SSPC will trip again. Removing and reapplying power to the 28VDC_IN pin will also reset the SSPC. If the CONTROL pin is at logic high when the 28VDC_IN power is cycled off/on, the SSPC will turn back on when the 28VDC_IN power is re-applied.

For all models except the SRPC7D28F, removing AUX_IN power will not change the on/off state of the SSPC mosfet. The last state commanded by CONTROL will be held until AUX_IN power is reapplied.

For the SRPC7D28F, removing AUX_IN power will immediately set the SSPC mosfet in the off state. When AUX_IN power is restored, the mosfet state will follow that commanded by the CONTROL input.

TECHNICAL DATA
DATASHEET 5100, Rev -

Logic Outputs

The STATUS and BIT/TRIP status outputs of the SSPC reflect the operating state of the SSPC. A logic high on the STATUS output indicates that the current drawn on the 28V_LOAD output is $\leq 10\%$ of rated load. A logic low shows that the current drawn from the 28V_LOAD output is $\geq 10\%$ of rated current. Because of load detection tolerances, a load that draws between 5% and 15% of rated current could result in either a high or low logic level on the STATUS output. Logic high on the BIT/TRIP output indicates that the Power Mosfet switch is on while a logic low indicates that the switch is off.

As can be seen in Table 6, of the 8 possible states for the combination of CONTROL, STATUS, and BIT/TRIP, only 4 states represent valid SSPC operation. The other 4 states indicate either a failed SSPC or, more likely, a short to Aux Common or a short to the AUX supply of one of the logic outputs. By comparing the CONTROL input with the STATUS and BIT/TRIP outputs, the user can determine whether or not the load is supposed to be ON, whether or not it's drawing current, and whether or not the STATUS and BIT/TRIP outputs are valid responses to the CONTROL input.

State 4 may be used as a normal operating mode for detecting loss of 28VDC IN voltage. Both STATUS and BIT/TRIP will be logic high if AUX power is applied but 28VDC IN power is not.

Table 6: CONTROL, STATUS & BIT/TRIP Truth Table

State	CONTROL	STATUS	BIT/TRIP	Comments
1	L	L	L	SSPC failure or shorted STATUS output to AUX Common
2	L	L	H	SSPC failure
3	L	H	L	Normal OFF condition
4	L	H	H	SSPC failure or 28VDC IN voltage too low
5	H	L	L	SSPC failure or shorted BIT/TRIP output to AUX Common
6	H	L	H	Normal ON condition with load current detected
7	H	H	L	Normal overcurrent trip condition
8	H	H	H	Normal ON condition with no load current detected

Wire Size

For transient or overload conditions, the transient or overload happens so quickly that heat is not transferred from the wire to the surroundings. The heat caused by the I^2R heating of the wire causes the temperature to rise at a linear rate controlled by the heat capacity of the wire. The equation for this linear rise in temperature, with respect to time, can be solved as: $I^2t = \text{constant}$. Every wire has an I^2t rating that's dependent on the temperature rise allowed and the diameter of the wire. If the I^2t rating of the SSPC or circuit breaker is less than the I^2t rating of the wire, then the SSPC or circuit breaker can protect the wire. The maximum I^2t rating for the 25A SSPC is 7.45×10^3 Amp²-Seconds. To select a wire size, it's simply a matter of determining the maximum temperature rise of the application, deciding whether or not the wire will be in a bundle, and use the information above.

TECHNICAL DATA
DATASHEET 5100, Rev -

Application Connections

The connections to the SSPC in a typical application are shown in Figure 12.

Figure 12: Typical Application

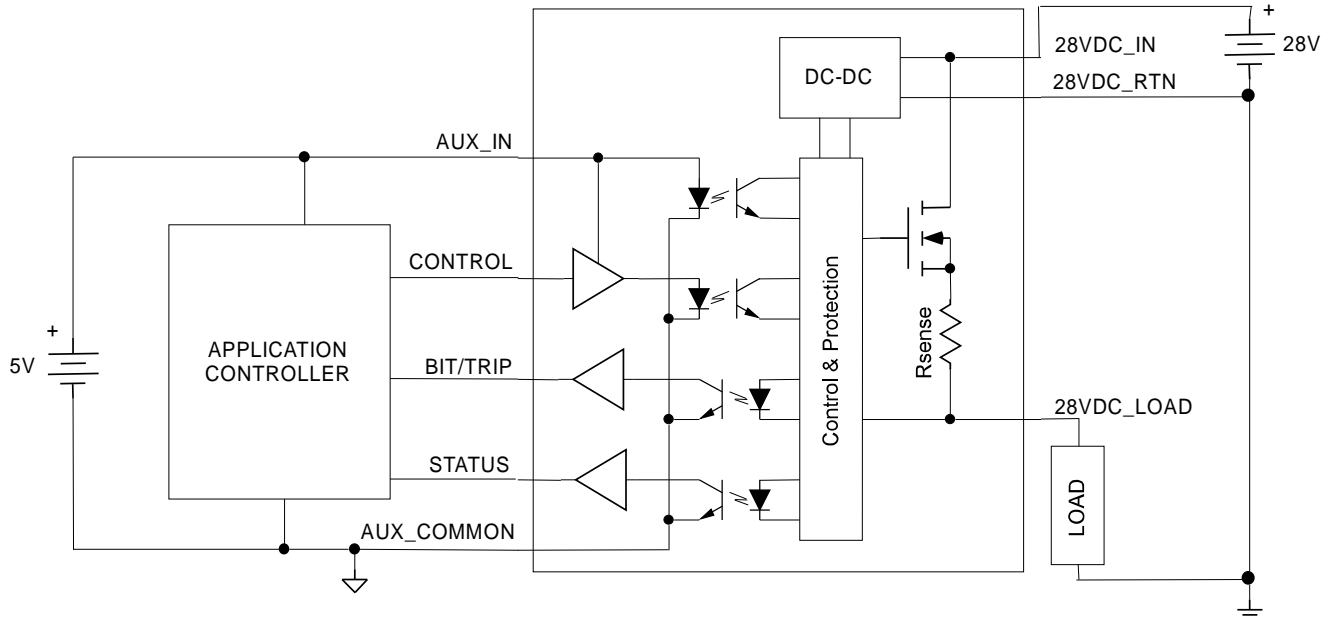

Rise Time & Fall Time

The rise and fall times of the SSPC are pre-set at the factory for a nominal 100 μ S (see Table 3 for min/max limits). The rise and fall times will vary linearly with supply voltage.

The SSPC's can turn on into a capacitive load without tripping. Limits on capacitance are shown in Table 7.

Table 7: Allowed Load Capacitance

Model	Clload Allowed
SRPC0.5D28	20 μ F
SRPC2D28	90 μ F
SRPC7D28	200 μ F
SRPC15D28	280 μ F
SRPC25D28	470 μ F
SRPC7D28F	200 μ F

Wiring and Load Inductance

Wiring inductance can cause voltage transients when the SSPC is switched off due to an overload. Generally, these transients are small but must be considered when long wires are used on either the 28VDC IN or 28V LOAD pins or both. A 10 foot length of wire in free air will cause a transient voltage of about 10 Volts when the 25A SSPC trips at an Instant Trip level of 180 Amps. At the rated load current of 25 Amps, the voltage transient will be about 1 Volt. If longer wire lengths are used, a transient suppressor may be used at the 28VDC IN pin and a power diode may be used at the 28VDC LOAD pin so that the total voltage between these pins is less than 100 V.

TECHNICAL DATA

DATASHEET 5100, Rev -

When powering inductive loads, the negative voltage transient at the 28VDC LOAD pin can cause the voltage between 28VDC IN and 28VDC LOAD to exceed the SSPC rating of 100 Volts and a power diode from the 28V DC LOAD pin to 28V RETURN must be used. The cathode of the power diode is connected to the 28VDC LOAD pin with the anode connected to 28V RTN . The power diode must be able to carry the load current when the SSPC switches off. Voltage transients due to wiring or load inductance are proportional to the operating current. Therefore, transients are less of a problem for the lower current SSPC models.

Paralleling

For example, putting two 25A SSPCs in parallel will not double the rating to 50 Amps. Due to differences in the $R_{ds(on)}$ of the Power Mosfets in the SSPCs, the current will not share equally. In addition, there are unit-to-unit differences in the trip curves so that two SSPCs in parallel may possibly trip at 35 Amps. Also, both SSPCs will not trip together; the SSPC carrying the higher current will trip first followed by the other SSPC. Multiple SSPCs may be used in parallel as long as these complexities are appreciated. Due not parallel different models of this series as the current sharing will not be predictable.

Layout

The current-carrying power circuit should be kept well away from the control circuit and other low-level circuits in the system. It's unlikely, but possible, that magnetic coupling could affect the control circuit when turning normal loads on and off. However, in the case of an overload, the magnetic coupling could be 10 times greater than with normal loads. Effects of such coupling could cause 'chattering' when turning on and off, oscillation, and the possibility of turning the SSPC back on after an overload. The SSPC is a Trip-Free device. Once tripped it will not turn back on until reset and commanded on again. Reset is accomplished by bringing the CONTROL pin low and turning the SSPC back on is accomplished by bringing the CONTROL pin high. Sufficient magnetic coupling between the current-carrying power circuit and the control circuit can negate the Trip-Free characteristic.

DISCLAIMER:

- 1- The information given herein, including the specifications and dimensions, is subject to change without prior notice to improve product characteristics. Before ordering, purchasers are advised to contact the Sensitron Semiconductor sales department for the latest version of the datasheet(s).
- 2- In cases where extremely high reliability is required (such as use in nuclear power control, aerospace and aviation, traffic equipment, medical equipment , and safety equipment) , safety should be ensured by using semiconductor devices that feature assured safety or by means of users' fail-safe precautions or other arrangement .
- 3- In no event shall Sensitron Semiconductor be liable for any damages that may result from an accident or any other cause during operation of the user's units according to the datasheet(s). Sensitron Semiconductor assumes no responsibility for any intellectual property claims or any other problems that may result from applications of information, products or circuits described in the datasheets.
- 4- In no event shall Sensitron Semiconductor be liable for any failure in a semiconductor device or any secondary damage resulting from use at a value exceeding the absolute maximum rating.
- 5- No license is granted by the datasheet(s) under any patents or other rights of any third party or Sensitron Semiconductor.
- 6- The datasheet(s) may not be reproduced or duplicated, in any form, in whole or part, without the expressed written permission of Sensitron Semiconductor.
- 7- The products (technologies) described in the datasheet(s) are not to be provided to any party whose purpose in their application will hinder maintenance of international peace and safety nor are they to be applied to that purpose by their direct purchasers or any third party. When exporting these products (technologies), the necessary procedures are to be taken in accordance with related laws and regulations.