

TECHNICAL DATA
DATA SHEET 4249, REV. A

Isolated Diode Array

Applications:

- High Frequency Data Lines
- RS-323 & RS-432 Networks
- LAN, Ethernet, I/O Ports
- IEC61000-4 compatible for ESD / EFT / Surge

Features:

- Protects up to 8 I/O Ports
- Isolated diodes eliminate crosstalk
- High Density Packaging
- High Breakdown Voltage; High Speed Switching (< 10 nsec)
- Low Capacitance; Low Leakage
- Hermetic Ceramic package
- TX, TXV, S level screening available

Maximum Ratings:

All ratings are at 25 °C unless otherwise noted

Reverse Breakdown Voltage	V_{BR}	Per diode @ 10 μ A	60	Vdc
Continuous Forward Current	I_o	Per diode, Derate at 2.4 mA/°C above +25 °C	300	mA
Peak Surge Current	I_{FSM}	Per diode, $t_p = 8.3$ msec	500	mA
Power Dissipation	P_D	Per Junction, Derate at 4.0 mW/°C above +25 °C	400	mW
Power Dissipation	P_D	Per Package, Derate at 4 mW/°C above 25 °C	500	mW
Max. Operating Temperature	T_J	-	-65 to +150	°C
Max. Storage Temperature	T_{stg}	-	-65 to +200	°C

Electrical Characteristics:

All ratings are per diode and at 25 °C unless otherwise noted

Max. Forward Voltage Drop	V_{F1}	Pulsed PW = 300 μ s	If = 100mAdc	1.00	V
	V_{F2}		If = 500mAdc	1.50	V
Max. Reverse Current	I_{R1}	@ $V_R = 40V$	0.1	μ A	
Max. Capacitance (Pin to Pin)	C_T	@ $V_R = 0V, f = 1MHz$	8.0	pF	
Max. Forward Recovery Time	T_{FR}	$I_F = 500mA$	40	ns	
Max. Reverse Recovery Time	T_{RR}	$I_F = I_R = 200$ mA dc, $I_{RR} = 20$ mA dc, $R_L = 100$ ohms	20	ns	

SENSITRON

TECHNICAL DATA
DATA SHEET 4249, REV. A

Mechanical Dimensions: in inches / mm

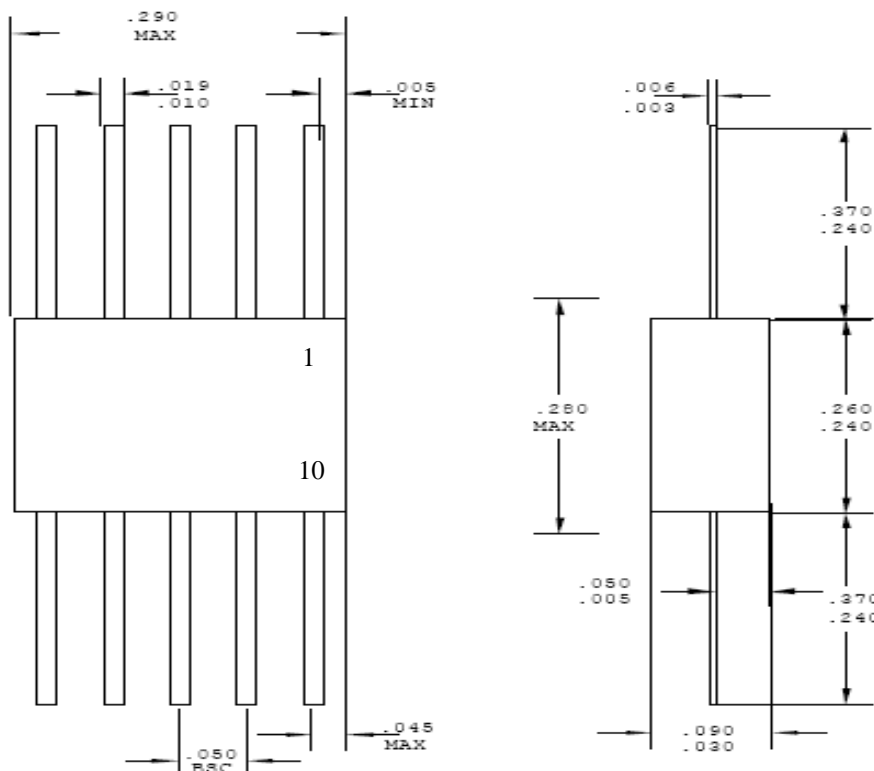

Electrical Schematic

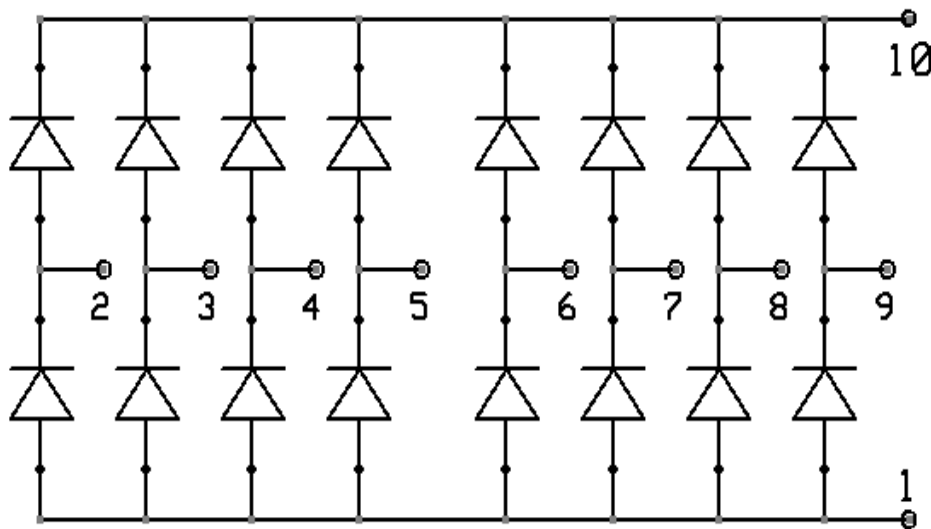

SENSITRON**TECHNICAL DATA
DATA SHEET 4249, REV. A**

DISCLAIMER:

- 1- The information given herein, including the specifications and dimensions, is subject to change without prior notice to improve product characteristics. Before ordering, purchasers are advised to contact the Sensitron Semiconductor sales department for the latest version of the datasheet(s).
- 2- In cases where extremely high reliability is required (such as use in nuclear power control, aerospace and aviation, traffic equipment, medical equipment, and safety equipment), safety should be ensured by using semiconductor devices that feature assured safety or by means of users' fail-safe precautions or other arrangement.
- 3- In no event shall Sensitron Semiconductor be liable for any damages that may result from an accident or any other cause during operation of the user's units according to the datasheet(s). Sensitron Semiconductor assumes no responsibility for any intellectual property claims or any other problems that may result from applications of information, products or circuits described in the datasheets.
- 4- In no event shall Sensitron Semiconductor be liable for any failure in a semiconductor device or any secondary damage resulting from use at a value exceeding the absolute maximum rating.
- 5- No license is granted by the datasheet(s) under any patents or other rights of any third party or Sensitron Semiconductor.
- 6- The datasheet(s) may not be reproduced or duplicated, in any form, in whole or part, without the expressed written permission of Sensitron Semiconductor.
- 7- The products (technologies) described in the datasheet(s) are not to be provided to any party whose purpose in their application will hinder maintenance of international peace and safety nor are they to be applied to that purpose by their direct purchasers or any third party. When exporting these products (technologies), the necessary procedures are to be taken in accordance with related laws and regulations.