

TECHNICAL DATA
Data Sheet 4977 Rev. A.1

Three-Phase IGBT BRIDGE, With Gate Driver and Optical Isolation

DESCRIPTION: A 600 VOLT, 140 AMP, THREE PHASE IGBT BRIDGE

ELECTRICAL CHARACTERISTICS PER IGBT DEVICE

(T_j=25°C UNLESS OTHERWISE SPECIFIED)

PARAMETER	SYMBOL	MIN	TYP	MAX	UNIT
IGBT SPECIFICATIONS					
Collector to Emitter Breakdown Voltage I _C = 2mA, V _{GE} = 0V	BV _{CES}	600	-	-	V
Continuous Collector Current T _C = 25 °C T _C = 80 °C	I _C	-	-	140 140	A
Pulsed Collector Current, 10mS	I _{CM}	-	-	200	A
Zero Gate Voltage Collector Current (For the module) V _{CE} = 600 V, V _{GE} =0V T _i =25°C V _{CE} = 480 V, V _{GE} =0V T _i =125°C	I _{CES}	-	-	2 15	mA mA
Collector to Emitter Saturation Voltage, I _C = 90A, V _{GE} = 15V, T _C = 25 °C T _C = 125 °C	V _{CE(SAT)}	-	1.5 1.8	1.8	V
IGBT Internal Turn On Gate Resistance			8.2		Ohm
IGBT Internal Turn Off Gate Resistance			6.2		Ohm
IGBT Internal Soft Shutdown Turn Off Gate Resistance			100		Ohm
Short Circuit Time, at 300V DC Bus			5		usec
DC Bus Voltage Rate of Rise With 15V Supply Removed, dv/dt		-	-	20	V/usec
Junction To Case Thermal Resistance	R _{θJC}	-	-	0.22	°C/W

MODULE TOTAL WEIGHT					
Estimated Total Weight		-	-	13	OZ

TECHNICAL DATA
Data Sheet 4977 Rev. A.1

Brake IGBT SPECIFICATIONS						
Continuous Collector Current (Limited by Terminals)	$T_C = 25\text{ }^\circ\text{C}$ $T_C = 90\text{ }^\circ\text{C}$	I_C	-	-	80 80	A
Pulsed Collector Current, 0.5mS		I_{CM}	-	-	250	A
IGBT Internal Gate Resistance				10		Ohm
IGBT Internal Gate Shunt Resistance				10		K Ohm
Junction To Case Thermal Resistance		$R_{\theta JC}$	-	-	0.28	$^\circ\text{C/W}$

ULTRAFAST DIODES RATING AND CHARACTERISTICS						
Diode Peak Inverse Voltage		PIV	600	-	-	V
Continuous Forward Current, $T_C = 90\text{ }^\circ\text{C}$		I_F	-	-	140	A
Forward Surge Current, $t_p = 10\text{ msec}$		I_{FSM}	-	-	400	A
Diode Forward Voltage, $I_F = 90\text{A}$		V_F	-	1.4	1.6	V
Diode Reverse Recovery Time ($I_F = 90\text{A}$, $V_{RR} = 300\text{V}$, $di/dt < 1500\text{ A}/\mu\text{s}$)		t_{rr}	-	150	200	nsec
Maximum Thermal Resistance		$R_{\theta JC}$	-	-	0.35	$^\circ\text{C/W}$

MODULE STORAGE AND OPERATING CONDITIONS						
Maximum operating Junction Temperature		T_{jmax}	-40	-	150	$^\circ\text{C}$
Maximum Storage Temperature		T_{jmax}	-55	-	150	$^\circ\text{C}$
Operating Altitude			-	-	50000	Ft
Vibration and shock requirements (1)						

TECHNICAL DATA
Data Sheet 4977 Rev. A.1

Gate Driver					
Supply Voltage, limits apply to Vcc, Vcc1, Vcc2, Vcc3	Vcc	12	15	18	V
Supply Input Current at Vcc, Pin 20, Without PWM Switching , with 10KHz PWM at Two Inputs			35 60		mA
Input On Current	HIN, LIN	2	5.0	8.0	mA
Opto-Isolator Logic High Input Threshold	I _{th}	-	1.6	2.0	mA
Input Reverse Breakdown Voltage	BV _{in}	5.0	-	-	V
Input Forward Voltage @ I _{in} = 5mA	V _F	-	1.5	1.7	V
Under Voltage Lockout, limits apply to Vcc, Vcc1, Vcc2, Vcc3	VCCUV	9.5	10.0	11.5	V
Internal Bootstrap Capacitor Value		10	-	-	uF
Desaturation Detection, High Input Threshold Voltage		7.0	8.0	9.0	V
Desaturation Detection, Low Input Threshold Voltage		6.0	7.0	8.0	V
Input-to-Output Turn On Delay	t _{ond}	-	750	900	nsec
Output Turn On Rise Time	t _r	-	110	150	
Input-to-Output Turn Off Delay	t _{offd}	-			
Output Turn Off Fall Time	t _f	-	1250	1400	
at VCC=300V, IC=70A, T _C = 25			100	130	
Dead Time Requirement, for Shoot Through Prevention		700	850		nsec
Opto-Isolator Input-to-Output Isolation Voltage, momentary	-	-	2500	-	V
Opto-Isolator Operating Input Common Mode Voltage				1000	V
Opto-Isolator Operating Input Common Mode Transient Immunity, with I _{in} > 5mA				10	KV/usec
Pin-To-Case Isolation Voltage, DC Voltage (Device will be tested at 3000V for 10 seconds)		-	2500	-	V

DC Bus Current Sensor (Bi-directional With Absolute Value Output)					
Shunt Resistor Value	-	-	0.50	-	mOhm
Current Amplifier Gain, Referenced to Gnd1			0.025		V/A
Current Amplifier DC Offset (Zero DC Bus Current)			0.030	0.080	V
Current Amplifier Response Time			5		usec

TECHNICAL DATA
Data Sheet 4977 Rev. A.1

+5V Output Power Supply					
Referenced to Gnd1					
+5V output power supply Referenced to Gnd1		4.75	5	5.25	V
Maximum load current				30	mA

+5V Input, Isolated Power Supply					
Referenced to Gnd2					
+5V Input, Isolated power supply ⁽²⁾ Referenced to Gnd2	VDD	4.75	5	5.25	V
Input Current			30		mA

Base Plate Temperature ⁽²⁾					
Base Plate Temperature Sensor Output Gain Referenced to Gnd2	Tco		6.25		mV/°C
Temperature Sensor Output DC Offset Referenced to Gnd2			+424		mV
Accuracy, at temperature range from - 40 °C to 125 °C			-	+/-4.0	°C

Phase A, Phase B, and Phase C Current Sensors (Bi-directional Output) ⁽²⁾					
Current Amplifier Gain Referenced to Gnd2			+/- 0.018		V/A
Current Amplifier DC Offset (Zero Phase Current) Referenced to Gnd2			2.5		V
Current Amplifier Outputs Isolation To Phase Lines, and to Gnd1			1500V		V

- (1) Unit is designed to meet**Vibration and Shock requirements, Mil-STD-810F shall be used. (514.5 and 516.5 methods respectively).**
- (2) Phase current sensors and base plate temperature sensor are floating sensors referenced to Gnd2. An isolated 5V power supply shall be used to power these sensors.

TECHNICAL DATA
Data Sheet 4977 Rev. A.1

Pinout

Pin #	Function	Pin #	Function
1	Isolated Input for Low-side IGBT of Phase A	23	TC _o Case Temperature Output with a gain of 6.25 mV/°C
2	Return for Input at 1	24	+5V Input Rtn (Signal Ground, Gnd2)
3	Isolated Input for High-side IGBT of Phase A	25	+5V Input
4	Return for Input at 3	26	IC _d DC offset of 2.5V for Differential Output Reading of Output at Pin 27
5	Isolated Input for Low -side IGBT of Phase B	27	IC _o , Phase C Current Sensor output
6	Return for Input at 5	28	IB _d DC offset of 2.5V for Differential Output Reading of Output at Pin 29
7	Isolated Input for High-side IGBT of Phase B	29	IB _o , Phase B Current Sensor output
8	Return for Input at 7	30,31	Brake Terminal. Brake Resistor Shall be Connected Between These Terminals and +VDC
9	Isolated Input for Low-side IGBT of Phase C	32	Brake IGBT Gate Input Brake IGBT Emitter input is internally connected to DC Bus return
10	Return for Input at 9	33 to 37	DC Bus return
11	Isolated Input for High-side IGBT of Phase C	38 to 42	DC Bus "+VDC" input
12	Return for Input at 11	43 to 46	Phase C output
13	Flt ⁽³⁾	47 to 50	Phase B output
14	SD ⁽³⁾	51 to 54	Phase A output
15	NC	55 ⁽⁴⁾	Rtn For Pin56
16	Idco	56 ⁽⁴⁾	Optional 15V for Phase C High Side Gate Driver
17	Flt Clear Input ⁽³⁾	57 ⁽⁴⁾	Rtn For Pin58
18	+5V Output	58 ⁽⁴⁾	Optional 15V for Phase B High Side Gate Driver
19	+15V Rtn (Signal Ground, Gnd1)	59 ⁽⁴⁾	Rtn For Pin60
20	+15V Input	60 ⁽⁴⁾	Optional 15V for Phase A High Side Gate Driver
21	IAd DC offset of 2.5V for Differential Output Reading of Output at Pin 22		
22	IA _o , Phase A Current Sensor output	Case	Isolated

(3) See Pin Description.

(4) Contact Factory for this option to be remove

TECHNICAL DATA
Data Sheet 4977 Rev. A.1

Device Marking

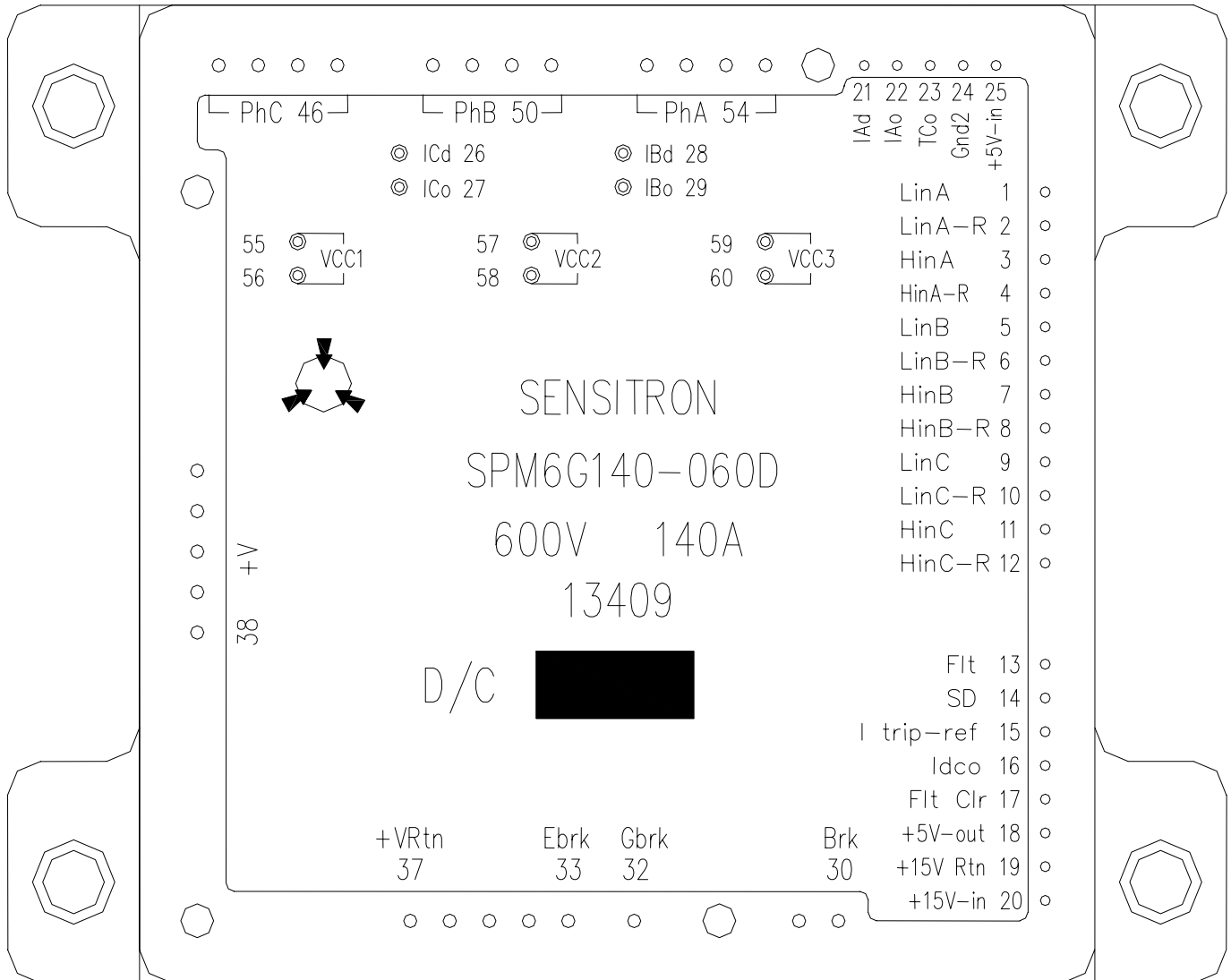

Figure 3. Device Pinout and Marking

TECHNICAL DATA
Data Sheet 4977 Rev. A.1

Normalized Thermal Impedance Curves for Both IGBTs and Diodes

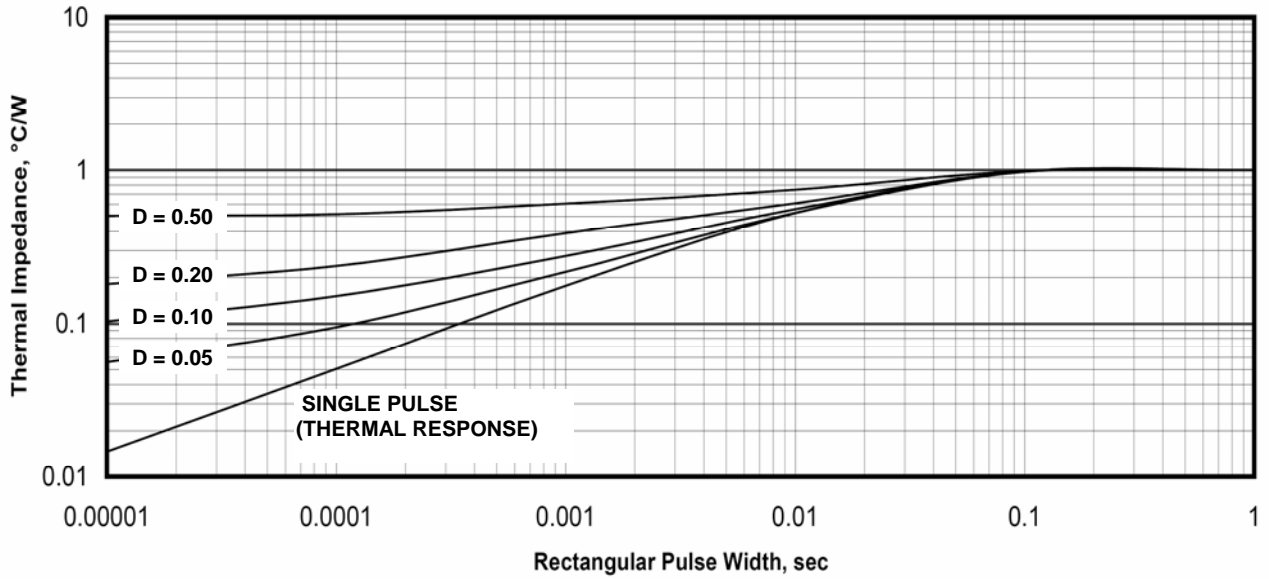

Figure 4. Normalized Transient Thermal Impedance, Junction-to-Case (IGBT)

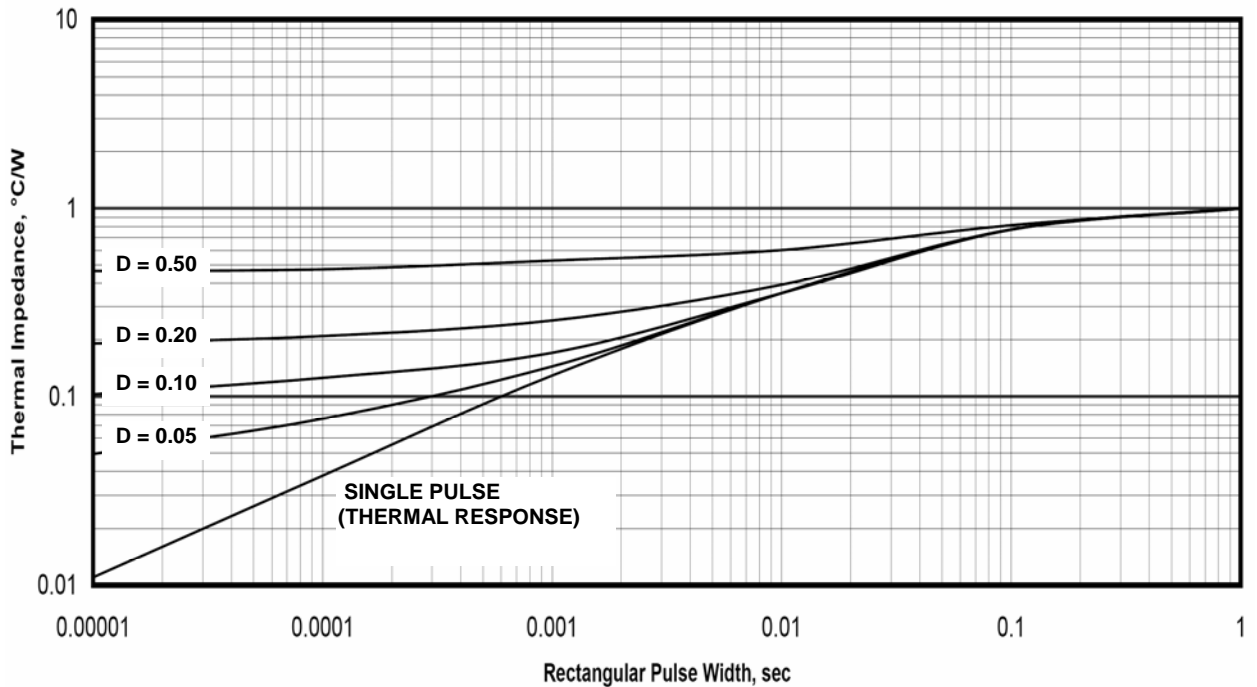

Figure 5. Normalized Transient Thermal Impedance, Junction-to-Case (Diode)

221 West Industry Court • Scottsdale, AZ 85260 • (480) 300-7000 FAX (480) 242-0700

• World Wide Web Site - <http://www.sensitron.com> • E-mail Address - sales@sensitron.com •

TECHNICAL DATA
Data Sheet 4977 Rev. A.1

Pin Descriptions

LinA (Pin 1), is an isolated drive input for Low-side IGBT of Phase A.

LinA-R (Pin 2), Return for Input at Pin1.

HinA (Pin 3), is an isolated drive input for High-side IGBT of Phase A.

HinA-R (Pin 4), Return for Input at Pin3.

LinB- (Pin 5), is an isolated drive input for Low-side IGBT of Phase B.

LinB-R (Pin 6), Return for Input at Pin5.

HinB (Pin 7), is an isolated drive input for High-side IGBT of Phase B.

HinB-R (Pin 8), Return for Input at Pin7.

LinC (Pin 9), is an isolated drive input for Low-side IGBT of Phase C.

LinC-R (Pin 10), Return for Input at Pin9.

HinC (Pin 11), is an isolated drive input for High-side IGBT of Phase C.

HinC-R (Pin 12), Return for Input at Pin11.

Recommended input turn-on current for all six drive signals is 5-8mA.

For higher noise immunity the tri-state differential buffer, DS34C87, is recommended as shown in Fig. 6.

Note : Connect LinA to non-inverting output for a non-inverting input logic.
Connect LinA to inverting output for an inverting input logic.

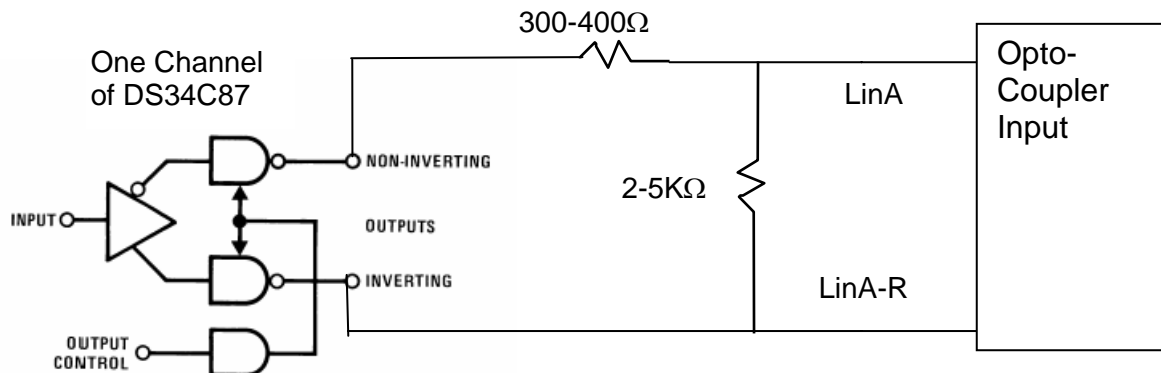

Fig. 6. Input Signal Buffer

TECHNICAL DATA

Data Sheet 4977 Rev. A.1

Flt (Pin 13), is a dual function input/output pin. It is an active low input. It is internally pulled high to +5V by 2.74K Ω . If pulled down, it will freeze the status of all the six IGBTs regardless of the Hin and Lin signals. As an output, Pin 13, reports desaturation protection activation. When desaturation protection is activated a low output for about 9 μ sec is reported. If any other protection feature is activated, it will not be reported by Pin 13.

SD (Pin 14), is a dual function input/output pin. It is an active low input. It is internally pulled high to +5V by 2.74K Ω . As a low input it shuts down all IGBTs regardless of the Hin and Lin signals. SD is internally activated due to desaturation protection only. Desaturation shutdown is a latching feature. SD can be used to shutdown all IGBTs except the brake IGBT by an external command. An open collector switch shall be used to pull down SD externally. Also, SD can be used as a fault condition output. Low output at SD indicates a latching fault situation.

NC (Pin 15), NC

Idco (Pin 16), is an absolute value current sense output of DC bus current. The sensor gain is 0.025V/A. The internal impedance of this output is 1K Ω , and internal filter capacitance is 1nF. The frequency response bandwidth of this signal is about 200KHz.

Flt-Clr(Pin 17), is a fault clear input. It can be used to reset a latching fault condition, due to desaturation protection.

Pin 17 an active high input. It is internally pulled down by 2.0K Ω . A latching fault due to desaturation can be cleared by pulling this input high to +5V by 200-500 Ω , or to +15V by 3-5K Ω , as shown in Fig. 9.

It is recommended to activate fault clear input for more than 300 μ sec at startup.

+5V Output (Pin 18), is a +5V output. Maximum output current is 30mA.

+15V Rtn (Pin 19), is signal ground, **Gnd1**. This pin is internally connected to DC Bus return.

No external connection shall be established between Signal Gnd1 and +VDC Rtn.

Gnd1 is isolated from Gnd2.

Note that Pins 13 to 18 are referenced to Gnd1.

Vcc (Pin 20), is the +15V input biasing supply connection for the controller. Under-voltage lockout keeps all outputs off for Vcc below 10.5V. Vcc pin should be connected to an isolated 15V power supply.

Vcc recommended limits are 14V to 16V , and shall not exceed 18V. The return of Vcc is pin 19.

Recommended power supply capability is about 70mA.

TECHNICAL DATA

Data Sheet 4977 Rev. A.1

IAd (Pin 21), is a +2.5V DC offset used for differential output reading of **IAo**.

IAo (Pin 22), is phase A hall current sensor output. The output can be measured between Pin22 and Pin 21 differentially. Zero current corresponds to zero output, current entering Phase A pins will produce positive output voltage at Pin22, and current out of Phase A pins will produce negative output voltage at Pin22.

Also, the output can be measured as single ended between Pin22 and Pin24. In this case zero current will correspond to 2.5V output, current entering Phase A pins will produce positive output voltage above 2.5V, and current out of Phase A pins will produce positive output voltage below 2.5V.

The sensitivity of this sensor is 0.015V/A.

TCo (Pin 23), is an analog output of case temperature sensor. The sensor output gain is 6.25mV/°C, with 424 mV DC offset. This sensor can measure both positive and negative °C. The internal impedance of this output is 2.74KΩ.

The internal block diagram of the temperature sensor is shown in Fig. 7.

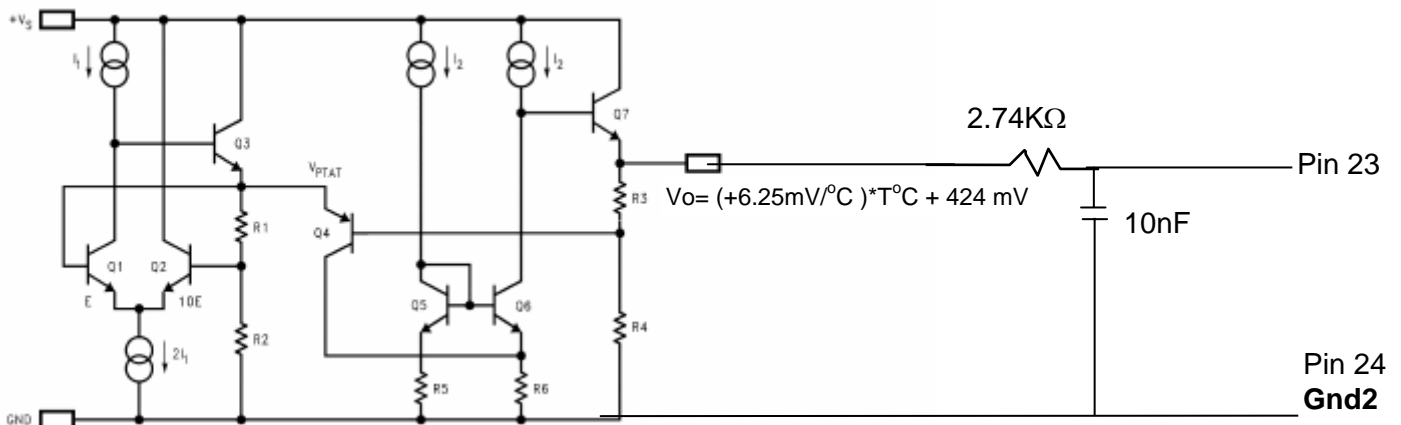

Fig. 7 Temperature Sensor Internal Block Diagram

The output voltage reading vs temperature will be:

- TCo = + 0.58V at Tc= +25°C
- TCo = + 1.205V at Tc= +125°C
- TCo = + 0.174V at Tc= -40°C

+5V-in Rtn (Pin 24), is signal ground, **Gnd2**. This pin is internally floating for flexibility. The phase current sensors and temperature sensor are referenced to Gnd2.

Gnd2 isolation from Gnd1 is over 1500V.

VDD, +5V-in (Pin 25), is the +5V input biasing supply connection for the phase current sensors and temperature sensor. Pin 25 should be connected to an isolated 5V power supply, recommended limits are 4.75V to 5.25V. The return of this input is pin 24.

Recommended power supply capability for VDD is about 50mA.

TECHNICAL DATA

Data Sheet 4977 Rev. A.1

ICd (Pin 26), is a +2.5V DC offset used for differential output reading of **ICo**.

ICo (Pin 27), is hall current sensor output for phase C. The output can be measured between Pin27 and Pin 26 differentially. Zero current corresponds to zero output, current entering Phase C pins will produce positive output voltage at Pin27, and current out of Phase C pins will produce negative output voltage at Pin27.

Also, the output can be measured as single ended between Pin27 and Pin24. In this case zero current will correspond to 2.5V output, current entering Phase C pins will produce positive output voltage above 2.5V, and current out of Phase C pins will produce positive output voltage below 2.5V.

The sensitivity of this sensor is 0.015V/A.

IBd (Pin 28), is a +2.5V DC offset used for differential output reading of **IBo**.

IBo (Pin 29), is hall current sensor output for phase B. The output can be measured between Pin29 and Pin 28 differentially. Zero current corresponds to zero output, current entering Phase B pins will produce positive output voltage at Pin29, and current out of Phase B pins will produce negative output voltage at Pin29.

Also, the output can be measured as single ended between Pin29 and Pin24. In this case zero current will correspond to 2.5V output, current entering Phase B pins will produce positive output voltage above 2.5V, and current out of Phase B pins will produce positive output voltage below 2.5V.

The sensitivity of this sensor is 0.015V/A.

Brk (Pins 30,31), is Brake Terminal. Brake Resistor shall be connected between these terminals and +VDC. If the brake resistor is inductive, a freewheeling diode shall be connected across this resistor.

Gbrk (Pin 32), is Brake IGBT Gate Input. Brake IGBT Emitter is internally connected to DC Bus return.

+VDC Rtn (Pins 33 to 37), is DC Bus return.

+VDC (Pins 38 to 42), is +DC Bus input.

PhC (Pins 43 to 46), is Phase C output.

PhB (Pins 47 to 50), is Phase B output.

PhA (Pins 51 to 54), is Phase A output.

TECHNICAL DATA

Data Sheet 4977 Rev. A.1

Pins 55 to 60 are optional. In addition to the internal bootstrap circuits, of Pins 55-60 can be used to supplement additional, 15V power supplies for the high side gate drivers of phases A,B,C. The internal bootstrap circuits will stay and be supplemented by the additional power supplies. Contact factory if these pins are not needed

Vcc1, Vcc2, Vcc3 recommended limits are 14V to 16V , and shall not exceed 18V.

Fig. 8 shows the connection for Vcc3. A diode Da shall be used to prevent current flow from Vcc to Vcc3 incase of voltage variations between the two supplies. Da also acts as an oring diode and provides blocking incase of Vcc3 failure. Ra soften the initial charging rate of the gate driver power supply.

Recommended power supply capability for Vcc1, Vcc2, Vcc3 is about 15mA.

Vcc1-Rtn (Pin 55) , is Phase C high-side gate driver 15V power supply return.

Vcc1 (Pin 56) , is Phase C high-side gate driver 15V power supply. This should be an isolated power supply. This is an option to replace the internal Bootstrap circuit.

Vcc2-Rtn (Pin 57) , is Phase B high-side gate driver 15V power supply return.

Vcc2 (Pin 58) , is Phase B high-side gate driver 15V power supply. This should be an isolated power supply. This is an option to replace the internal Bootstrap circuit.

Vcc3-Rtn (Pin 59) , is Phase A high-side gate driver 15V power supply return.

Vcc3 (Pin 60) , is Phase A high-side gate driver 15V power supply. This should be an isolated power supply. This is an option to replace the internal Bootstrap circuit.

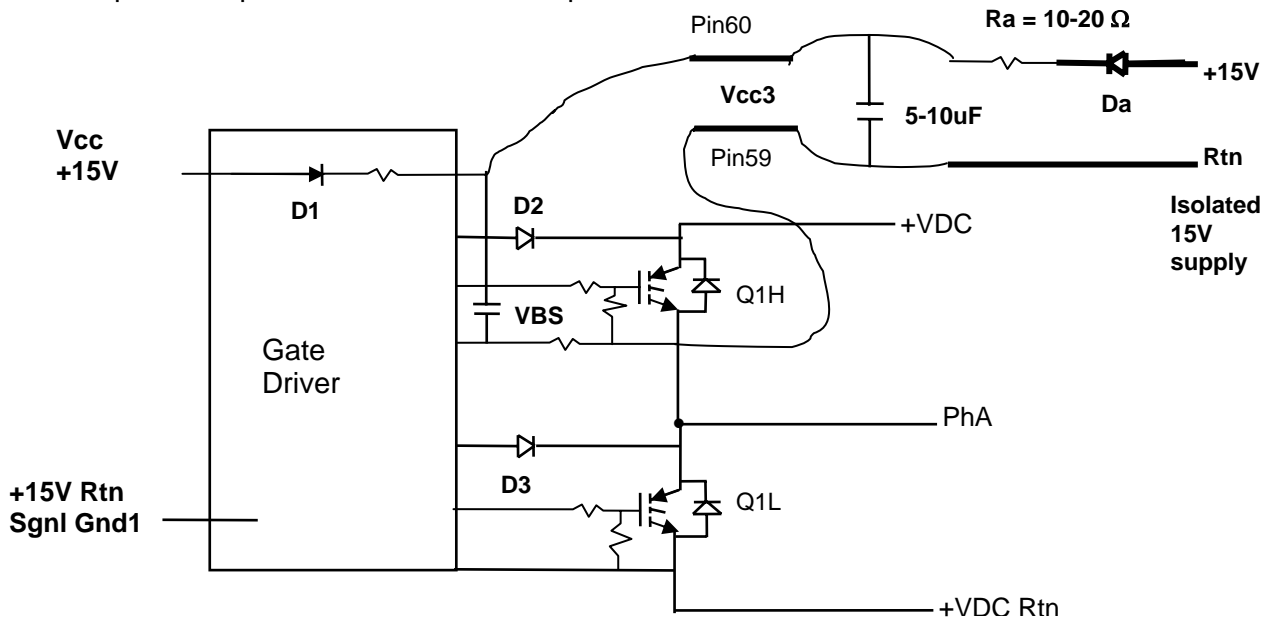

Figure 8. Floating 15V Power Supply Connection for High-Side Gate Drive Of PhA

TECHNICAL DATA

Data Sheet 4977 Rev. A.1

Application Notes

a- System Start Up Sequence:

Activate fault clear input for about **300 μsec** at startup. The micro-controller enable output is inverted and fed to the second DS34C87 control input. When the controller is in disable mode, the Flt-clr is enabled and Phase C low-side IGBT is turned on. This allows for the bootstrap circuit of the high-side IGBT of Phase C to be charged. At the same time, the high-side bootstrap circuits of Phases A and B will charge through the motor winding. Once the controller is enabled, PWM signals of all channels should start.

Fig. 9 shows a recommended startup circuit.

Notes:

- 1- Gnd1 and Gnd2 are isolated grounds from each other.
- 2- The +5V power supply used for DS34C87 is an isolated power supply.
- 3- The +15V power supply used for **SPM6G140-060D** is an isolated power supply.

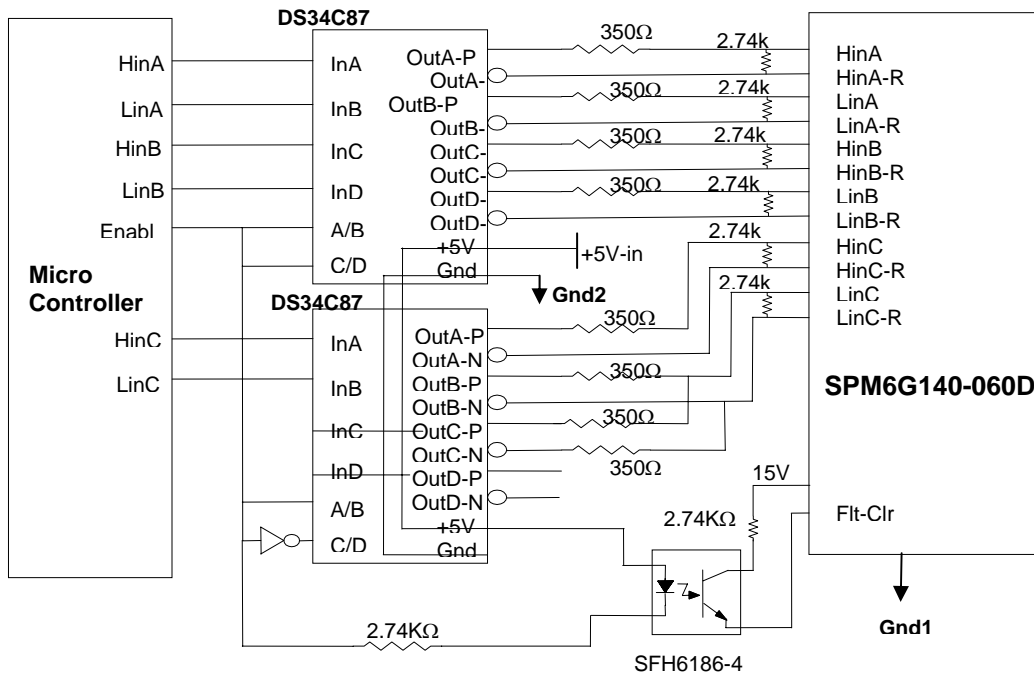

Fig. 9 Input Interface and Startup Circuit

Truth Table For DS34C87

Input	Control Input	Non-Inverting Output	Inverting Output
H	H	H	L
L	H	L	H
X	L	Z	Z

TECHNICAL DATA
Data Sheet 4977 Rev. A.1

To increase the circuit noise immunity, an active bias circuit is used to lower R1 and R2 when the corresponding IGBT is off by monitoring the input voltage at both DSH, DSL inputs. If the inputs at DSH drops below 7V the active bias is disabled. The active bias circuits result in reducing R1 or R2 to about 110 Ω when the corresponding input is above 8V, as shown in Fig. 11. This active circuit results in higher noise immunity.

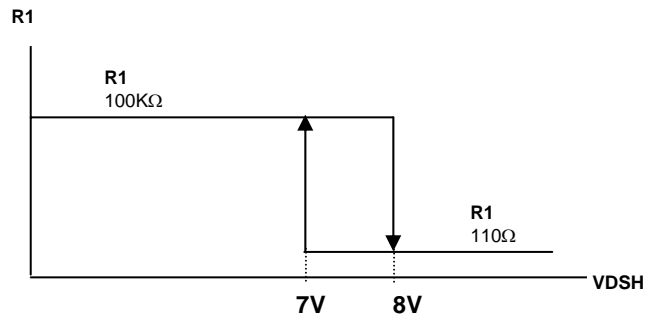

Figure 11. Active Bias for DSH and DSL Internal Inputs

d- Limitation With Trapezoidal Motor Drive

In trapezoidal motor drives, two phases are conducting while the third phase is off at any time. In Fig. 12 shows the voltage waveform across one phase, during intervals t1 and t2, the IGBT is off while the active bias circuit is above 8V, and below 15V. This results in activating the active pull up circuit and reducing the corresponding R1 or R2 down to about 110 Ω. A high current will flow from VCC or VBS through R2 or R1 and the motor winding during intervals t1, and t2. This results in draining the bootstrap capacitor voltage quickly.

- **Contact the factory for adjustments to satisfy trapezoidal motor drive applications using this module. The adjustment will disable the internal pull up circuit.**

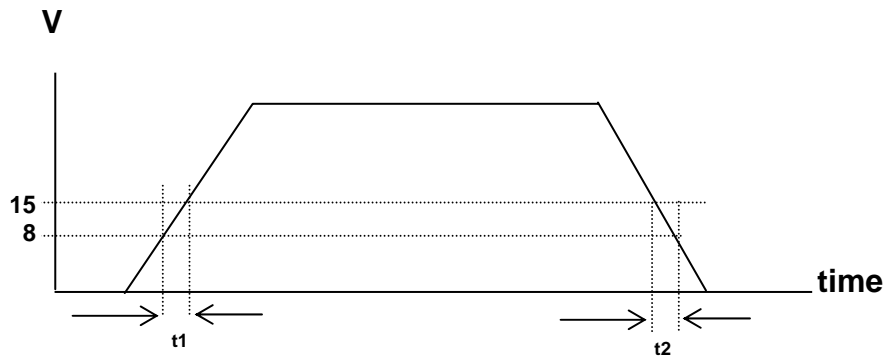

Figure 12. Active Bias for DSH and DSL Internal Inputs

TECHNICAL DATA

Data Sheet 4977 Rev. A.1

R1 and R2 are set to be 100KΩ. Lower value of R1 will overload the bootstrap circuit and reduce the bootstrap capacitor holding time.

Cleaning Process:

Suggested precaution following cleaning procedure:

If the parts are to be cleaned in an aqueous based cleaning solution, it is recommended that the parts be baked immediately after cleaning. This is to remove any moisture that may have permeated into the device during the cleaning process. For aqueous based solutions, the recommended process is to bake for at least 2 hours at 125°C.

Do not use solvents based cleaners.

Recommended Soldering Procedure:

Signal pins 1-29, 55-60: 210C for 10 seconds max

Power pins 30-54: 260C for 10 seconds max. Pre-warm module to 125C to aid in power pins soldering.

DISCLAIMER:

1- The information given herein, including the specifications and dimensions, is subject to change without prior notice to improve product characteristics. Before ordering, purchasers are advised to contact the Sensitron Semiconductor sales department for the latest version of the datasheet(s).

2- In cases where extremely high reliability is required (such as use in nuclear power control, aerospace and aviation, traffic equipment, medical equipment, and safety equipment), safety should be ensured by using semiconductor devices that feature assured safety or by means of users' fail-safe precautions or other arrangement.

3- In no event shall Sensitron Semiconductor be liable for any damages that may result from an accident or any other cause during operation of the user's units according to the datasheet(s). Sensitron Semiconductor assumes no responsibility for any intellectual property claims or any other problems that may result from applications of information, products or circuits described in the datasheets.

4- In no event shall Sensitron Semiconductor be liable for any failure in a semiconductor device or any secondary damage resulting from use at a value exceeding the absolute maximum rating.

5- No license is granted by the datasheet(s) under any patents or other rights of any third party or Sensitron Semiconductor.

6- The datasheet(s) may not be reproduced or duplicated, in any form, in whole or part, without the expressed written permission of Sensitron Semiconductor.

7- The products (technologies) described in the datasheet(s) are not to be provided to any party whose purpose in their application will hinder maintenance of international peace and safety nor are they to be applied to that purpose by their direct purchasers or any third party. When exporting these products (technologies), the necessary procedures are to be taken in accordance with related laws and regulations.